

# 2018 Genel Ürün Kataloğu

Products Overview 2018



**bm** ■■■<sup>®</sup>  
**CAM**  
DONANIMLARI

**colcom**  
GROUP

**colcom**<sup>®</sup> **minusco**<sup>®</sup> **SADEV**<sup>®</sup>  
Oliodynamic Hinges Glass Channel Network ARCHITECTURAL SYSTEMS  
COLCOM GROUP

MADE IN ITALY

**colcom**  
G R O U P

colcom® minusco® SADEV®  
Oildynamic Hinges Glass Oriented Network ARCHITECTURAL SYSTEMS COLCOM GROUP

BM Cam Donanımları, inşaat sektörü içinde iç bölme sistemleri ve cam donanımları alanında faaliyet yürütmektedir. Değişen kullanıcı ihtiyaçlarını ve gelişen teknolojik süreci etkin bir biçimde takip eden şirketimiz; ofis bölme sistemleri, kapı sistemleri, duş kabini sistemleri ve cam donanımları üzerine geniş ürün yelpazesi ile hizmet vermektedir.

Yenilikçi ve fonksiyonel ürünleri siz kullanıcılarımızın hizmetine sunmayı hedefleyen şirketimiz, bu kapsamda dünyanın önde gelen cam donanımı üreticisi olan İtalyan Minusco firmasının Türkiye ve bölge ülkeler distribütörlüğünü yapmaktadır. Sektörde öncü olma hedefimizi durmaksızın sürdürerek, siz değerli müşterilerimize kaliteli, hızlı ve güvenilir hizmet sunmak için çalışmalarımızı aralıksız devam ettirmekteyiz.

BM Glass Hardware, deals at the area of interior partition systems and glass hardware production in the sector of construction, our firm effectly observes the changing of consumer demands by taking into consideration of growing technological environment. The main product of our firm is office partition systems, door systems, shower cabins and glass hardwares.

Our strategy is to present the innovative and functional products to the consumers. We are the official distributor of Turkey and regional countries, of leader brand Italian Minusco company. We always dedicate our efforts to be the leader at the sector and provide the best service to our precious customers.

Bilgi ve detaylı teknik broşürler için [www.bmofis.com](http://www.bmofis.com) daki genel kataloğa bakınız.  
For Information and detailed technical leaflets look to the general catalogue on the web site [www.bmofis.com](http://www.bmofis.com)

# Glass Oriented Network

**bm** CAM®  
D O N A N I M L A R I

Commercial network aimed at sale and distribution of glass accessories for interior architecture. Minusco, active both in Italy and in the main international markets, through numerous subsidiaries and a network of partner companies exclusively sells Colcom products and offers selected articles of other prestigious brands. Commercial operations are facilitated by a system of e-commerce on the website [www.minusco.com](http://www.minusco.com).



Rete commerciale finalizzata alla vendita e distribuzione di accessori del vetro per architettura d'interni. Minusco, attiva sia in Italia che nei principali mercati internazionali, attraverso le numerose filiali e una rete capillare di aziende partner vende in esclusiva i prodotti Colcom e offre articoli selezionati di altri prestigiosi marchi. Le operazioni commerciali sono facilitate da un sistema di e-commerce presente sul sito [www.minusco.com](http://www.minusco.com).

colcom® SADEV®  
Oildynamic Hinges ARCHITECTURAL SYSTEMS COLCOM GROUP

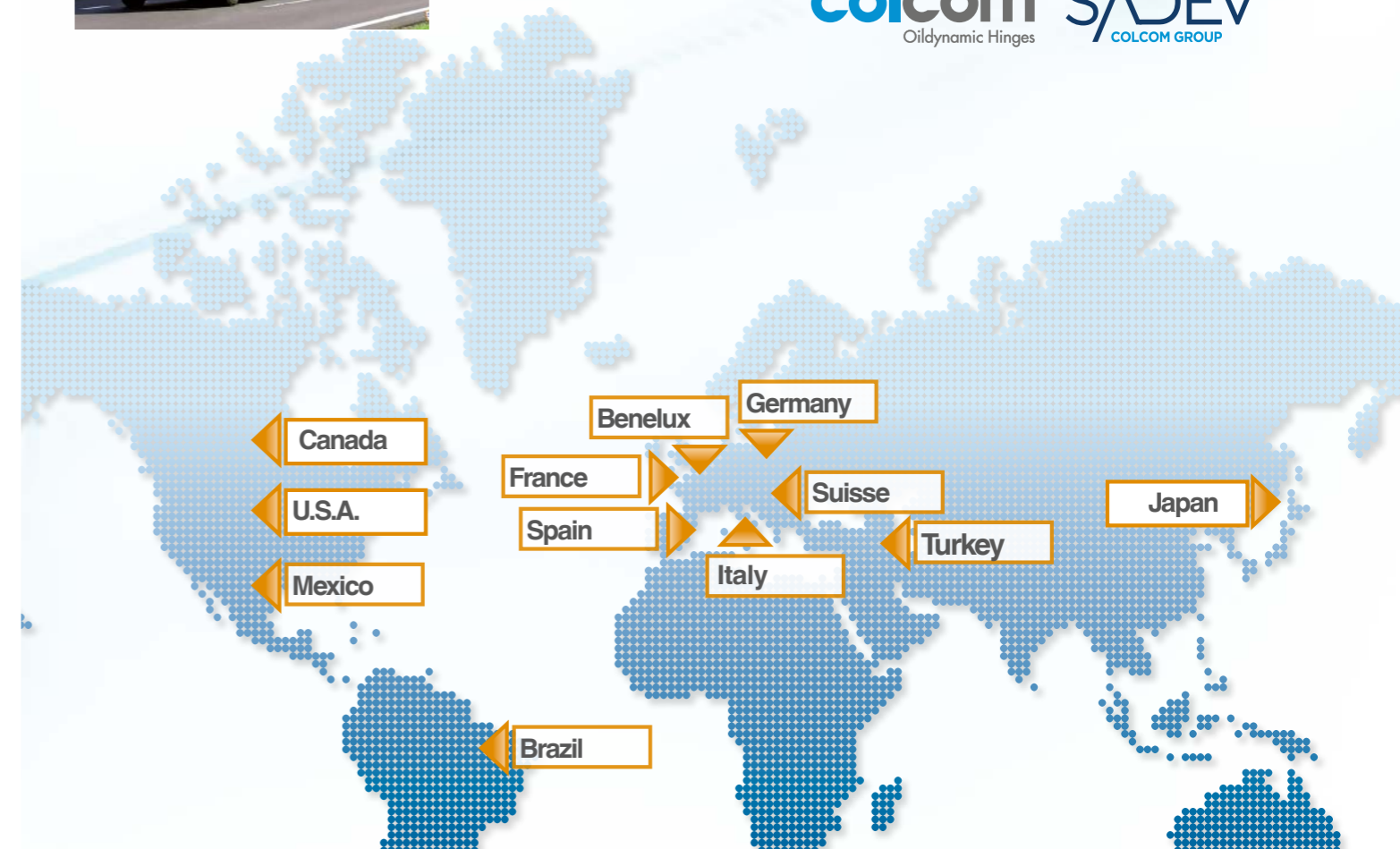

- **Duř Kabini Aksesuarları**  
Shower box components  
Box Doccia ..... pag.05
- **İç Kapı Menteřeleri**  
Hinges for inner doors  
Porte Interne..... pag.27
- **Cam Bölme Profil ve Aksesuarları**  
Glass wall profiles and accessories  
Partizioni e Sistemi profili..... pag.39
- **Sürme Sistemleri**  
Sliding systems  
Porte Scorrevoli..... pag.47
- **Dıř Kapı Menteřeleri**  
Hinges for outer doors  
Porte Esterne..... pag.57
- **Kilitler ve Kapı Kolları**  
Locks and handles  
Serrature e maniglioni..... pag.71
- **Mobilya Aksesuarları**  
Show windows and angle brackets  
Vetrine e reggimensola..... pag.85
- **Dıř Mekan Aksesuarları**  
Street furniture  
Arredo urbano ..... pag.87



## DUř KABİNİ AKSESUARLARI

Complements for Shower Boxes  
Complementi per Box Duccia

# Bilobina Centrale

Seri - Series

0° +90° -90°

DUŞ KABINI İÇİN HİDROLİK SİSTEM

HYDRAULIC SYSTEM FOR SHOWER BOX - OLEODINAMICA SISTEMA PER BOX DOCCIA

## art. 825E00



- Duvar cam hidrolik menteşe , entegre otomatik kapanış mekanizması. 0° ±3° hiza ayar.
- Glass-wall hydraulic hinge with integrated closing automatism. Alignment adjustable to 0° ±3°.
- Cerniera idraulica vetro-muro con automatismo di chiusura integrato. Regolazione allineamento 0° ±3°.h

## art. 825E10



- Duvar cam hidrolik menteşe , entegre otomatik kapanış mekanizması. Asimetrik bağlantı plakası. 0° ±3° hiza ayar.
- Glass-wall hydraulic hinge with integrated closing automatism. Off-set wing. Alignment adjustable to 0° ±3°.
- Cerniera idraulica vetro-muro con automatismo di chiusura integrato. Aletta spostata. Regolazione allineamento 0° ±3°.h

## art. 825E50



- Cam cama hidrolik menteşe , entegre otomatik kapanış mekanizması. 0° ±3° hiza ayar.
- Glass to glass hydraulic hinge with integrated closing automatism. Alignment adjustable to 0° ±3°.
- Cerniera idraulica vetro-vetro con automatismo di chiusura integrato. Regolazione allineamento 0° ±3°.h



# Bilobina Seri - Series

0° +90°

DUŞ KABİNİ İÇİN HİDROLİK SİSTEM  
HYDRAULIC SYSTEM FOR SHOWER BOX - OLEODINAMICA SISTEMA PER BOX DOCCIA



art. 815E10N

- Dus kabinleri için cam-duvar hidrolik menteşe. Binilli kapılar için. +90°'de durur.
- Hydraulic hinge glass to wall for shower boxes. For doors with stop. Stop at +90°.
- Cerniera oleodinamica vetro-muro per box doccia. Per ante in battuta. Stop a +90°.



art. 815E50N

- Dus kabinleri için cam-cama hidrolik menteşe. Binilli kapılar için. +90°'de durur.
- Hydraulic hinge glass glass for shower boxes. For doors with stop. Stop at +90°.
- Cerniera oleodinamica vetro-vetro per box doccia. Per ante in battuta. Stop a +90°.



# Biloba BT Seri - Series

NEMLİ ORTAMLAR İÇİN AYRICA BUHAR ODASI VE HAMAM GİBİ YÜKSEK SICAKLIKTAKİ UYGULAMALAR İÇİN  
FOR APPLICATIONS IN DAMP ENVIRONMENTS AND ALSO HIGH TEMPERATURE LIKE STEAM ROOMS AND TURKISH BATHS  
PER AMBIENTI UMIDI CON ALTE TEMPERATURE COME SAUNE E BAGNI TURCHI

0° +90° -90°



art. 8010BT

- Kapanma hızı ayarlanabilir hidrolik menteşe.
- Hydraulic hinge with adjustment of the closing speed.
- Cerniera oleodinamica con regolazione della velocità di chiusura.



art. 8011BT

- Kapanma hızı ayarlanabilir hidrolik menteşe. (tek yönlü bağlantı plakası ile).
- Hydraulic hinge (with offset fixing wing) with adjustment of the closing speed.
- Cerniera oleodinamica (con aletta spostata) con regolazione della velocità di chiusura.



art. 8015BT

- Kapı kapanma hızı ayarlanabilir hidrolik menteşe. (cam-cama).
- Hydraulic hinge (glass to glass) with adjustment of the closing speed of the door.
- Cerniera oleodinamica (vetro-vetro) con regolazione delle velocità di chiusura dell'anta.

0° +90°



art. 8060BT

- Binilli kapı için kapanma hızı ayarlanabilir hidrolik menteşe.
- Hydraulic hinge with adjustment of the closing speed of door with stop.
- Cerniera oleodinamica con regolazione delle velocità di chiusura dell'anta per porte in battuta.



# Sauna set - kit

0° +90°

**SAUNA KAPILARI İÇİN SET - SET FOR SAUNA DOORS  
KIT PER PORTA SAUNA**

**art. KSN8060**

- Sauna seti 2 Biloba 8060BT menteşe ve 1 ahşap topuz 5006BT içermektedir.
- The set for sauna is combined of 2 Biloba hinges 8060BT and one wooden knob ref. 5006BT.
- Il kit per l'ambiente sauna è composto da 2 cerniere Biloba 8060BT in abbinamento al pomolo in legno art.5006BT.

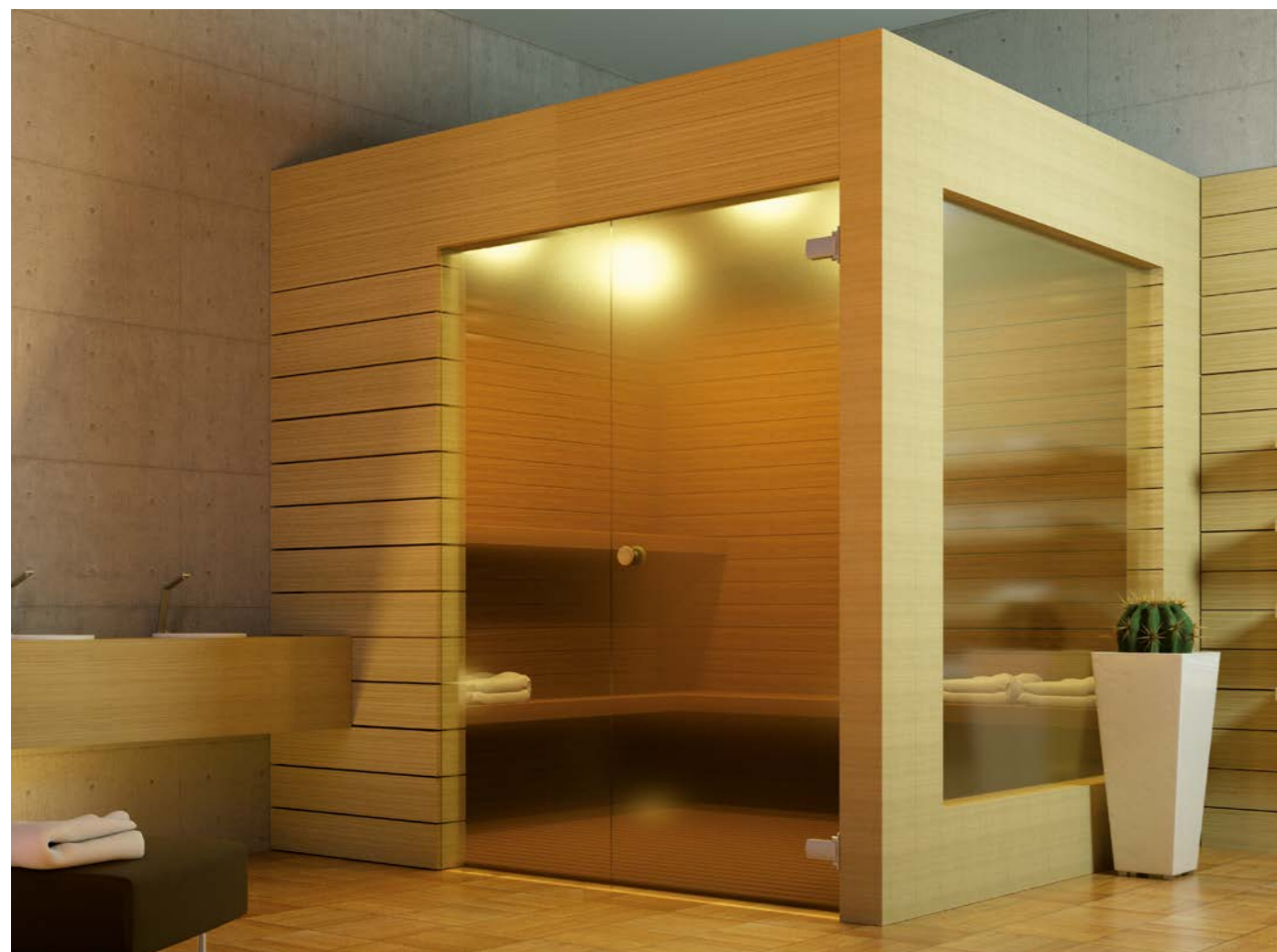
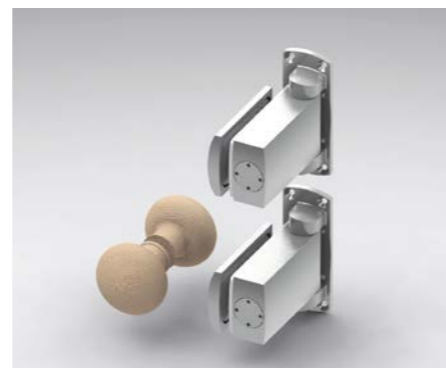

# Buhar Odası set - kit

0° +90°

**BUHAR ODALARI (HAMAM) İÇİN SET - SET FOR STEAM BATHS  
KIT PER PORTA BAGNO TURCO**

**art. KBT8061**

- Buhar odası seti 2 Biloba 8061BT menteşe ve Espro profilleri , 2PCC08k + 2 PCC03K her ikisi de 3,2m'lik olarak içermektedir. Bu profiller buharın kaçışını engellemektedir.
- The set is combined of 2 Biloba hinges 8061BT and Espro profiles, 2 PCC08K + 2 PCC03K both in lengths of 3,2 meters. These profiles avoid steam runoff.
- Il kit è composto da 2 cerniere Biloba 8061BT e dai profili Espro, 2 PCC08K + 2 PCC03K entrambi da 3,2 metri, che consentono di contenere l'uscita del vapore.



# 850 Seri - Series

0° +90° -90°

## YAYLI MENTEŞELER CLICKING HINGES - CERNIERE A SCATTO



### art. 8500

- Yaylı Menteşe.
- Clicking hinge.
- Cerniera a scatto.



### art. 8501

- Tek yönlü bağlantı plakalı yaylı menteşe.
- Clicking hinge with offset fixing wing.
- Cerniera a scatto con aletta spostata.



### art. 8505

- Cam-cama 180° yaylı menteşe.
- Clicking hinge glass to glass 180°.
- Cerniera a scatto vetro-vetro 180°.



### art. 8506

- Cam-cama 90° yaylı menteşe.
- Clicking hinge glass to glass 90°.
- Cerniera a scatto vetro-vetro 90°



### art. 8507

- Cam-cama 135° yaylı menteşe.
- Clicking hinge glass to glass 135°.
- Cerniera a scatto vetro-vetro 135°



# 850R Seri - Series

0° +90° -90°

## AYARLANABİLİR YAYLI MENTEŞELER ADJUSTABLE CLICKING HINGES - CERNIERE A SCATTO REGOLABILI



### art. 8500R

- Ayarlanabilir yaylı menteşe.
- Adjustable clicking hinge.
- Cerniera a scatto regolabile.



### art. 8501R

- Tek yönlü bağlantı plakalı ayarlanabilir yaylı menteşe.
- Adjustable clicking hinge with offset fixing wing.
- Cerniera a scatto regolabile con aletta spostata.



### art. 8505R

- Cam-cama 180° ayarlanabilir yaylı menteşe.
- Adjustable clicking hinge glass to glass 180°.
- Cerniera a scatto regolabile vetro-vetro 180°.



### art. 8506R

- Cam-cama 90° ayarlanabilir yaylı menteşe.
- Adjustable clicking hinge glass to glass 90°.
- Cerniera a scatto regolabile vetro-vetro 90°.



### art. 8507R

- Cam-cama 135° ayarlanabilir yaylı menteşe.
- Adjustable clicking hinge glass to glass 135°.
- Cerniera a scatto regolabile vetro-vetro 135°.



# 856 Seri - Series

0° +90°

**KESİNTİSİZ FİTİL KULLANILABİLEN YAYLI MENTEŞELER**  
**CLICKING HINGES WITHOUT CUT ON THE SEAL - CERNIERE A SCATTO**



**art. 8560**

- Yaylı menteşe.
- Clicking hinge.
- Cerniera a scatto.



**art. 8565**

- Cam-cama 180° yaylı menteşe.
- Clicking hinge glass to glass 180°.
- Cerniera a scatto vetro-vetro 180°.



**art. 8566**

- Cam-cama 90° yaylı menteşe.
- Clicking hinge glass to glass 90°.
- Cerniera a scatto vetro-vetro 90°.



**art. 8567**

- Cam-cama 135° yaylı menteşe.
- Clicking hinge glass to glass 135°.
- Cerniera a scatto vetro-vetro 135°.



# 840 Seri - Series

0° +180°

**YAN MENTEŞELER**  
**SIDE HINGES - CERNIERE LATERALI**



**art. 8400**

- Duş kabini menteşesi.
- Hinge for shower box.
- Cerniera per box doccia.



**art. 8401**

- Cam-cama 135°-180° menteşe.
- Hinge glass to glass 135°-180°.
- Cerniera vetro-vetro 135°-180°.



**YAN MENTEŞELER**  
**SIDE HINGES - CERNIERE LATERALI**



**art. 8410N**

8410NR = sağ - right - destra  
8410NL = sol - left - sinistra

- Duvardan cama asansörlü menteşe.
- Hinge wall to glass with lifting of door at opening.
- Cerniera vetro-muro con alzata in apertura.



**art. 8411N**

8411NR = sağ - right - destra  
8411NL = sol - left - sinistra

- Cam-cama asansörlü menteşe.
- Hinge glass-glass with lifting of door at opening.
- Cerniera vetro-vetro con alzata in apertura.





## DAİRESEL KESİTLİ ve DİDÖRTGEN KESİTLİ SÜRME SİSTEM SLIDING SYSTEM WITH ROUND AND RECTANGULAR SECTION - SISTEMA SCORREVOLE



### art. BZ00 - BZQ0

- Hip Zac köşe seti. Duş teknesi ebadı 800÷900mm.
- Hip Zac corner kit. Shower tray size 800÷900mm.
- Kit Hip-zac ad angolo. Per piatto 800÷900mm.



### art. BZ03 - BZQ3

- Hip Zac niş seti 1200-1800mm.
- Hip Zac niche kit 1200-1800mm.
- Kit Hip-zac per box doccia in nicchia da 1200 a 1800mm.



### art. BZ06 - BZQ6

- Hip Zac 2 sabit yan panelli ön cephe seti 1200-1800mm.
- Hip Zac kit with 2 fixed glass panels 1200-1800mm.
- Kit Hip-zac per box doccia con 2 spalle in vetro da 1200 a 1800mm.



### art. BZ07 - BZQ7

- Hip Zac 1 sabit yan panelli ön cephe seti 1200-1800mm.
- Hip Zac kit with 1 fixed glass panel 1200-1800mm.
- Kit Hip-zac per box doccia con 1 spalla in vetro da 1200 a 1800mm.



### art. BZ09 - BZQ9

- Hip Zac küvet üstü set 1000-2000mm.
- Hip Zac kit for bath-tubs 1000-2000mm.
- Kit Hip-zac per sopravasca da 1000 a 2000mm.



## SÜRME SİSTEM SLIDING SYSTEM - SISTEMA SCORREVOLE A SEZIONE

Duş kabinleri için dizayn edilmiş olan PIUMA sürme sistemin en belirgin özellikleri; sabit ve kayar camın arasındaki mesafe minimuma indirgenmiştir ; şeffaflık ve zarafetin ön planda olduğu bu sürme sistemde geniş camlar ağırlık problemi oluşturmadan kullanılabilir; 6/8mm cam için dizayn edilmiştir; alüminyum olarak üretilmiş olup parlak yüzey olarak mevcuttur; köşe profilleri paslanmaz çeliktir; minimum 80x80cm ve 100x180cm ölçülerde olup max. geçiş mesafesi 88cm'e kadar çıkabilir.



art. D15E00

- 2 sürme kanatlı köşe seti
- Corner set with two sliding doors



art. D15E30

- Tek kanatlı duvar içi sürme set
- Niche set with single sliding door



art. D15E70

- Tek sürme kanatlı köşe seti
- Corner set with single sliding door



art. D15E60

- 2 yan duvar sabit camlı tek kanat sürme
- Single sliding door with two fixed side glazings



## Bağlantı Elemanları ANGULAR FITTING and CLAMPS - Angolari e Morsetti



art. 4410

- Duvardan cama 90° açılı bağlantı elemanı.
- Angular fitting wall to glass 90°.
- Angolare muro-vetro 90°.



art. 4411

- Cam-cama 90° açılı bağlantı elemanı.
- Angular fitting glass to glass 90°.
- Angolare vetro-vetro 90°.



art. 4414

- Duvardan cama 90° açılı küçük bağlantı elemanı.
- Small angular fitting wall to glass 90°.
- Angolare piccolo muro-vetro 90°.



art. 4415

- Cam-cama 90° açılı küçük bağlantı elemanı.
- Small angular fitting glass to glass 90°.
- Angolare piccolo vetro-vetro 90°.



art. 4428

- Duvardan cama ayarlanabilir açılı bağlantı elemanı.
- Adjustable angular fitting wall to glass.
- Angolare muro-vetro regolabile.



art. 4429

- Cam-cama açısı ayarlanabilir bağlantı elemanı.
- Adjustable angular fitting glass to glass.
- Angolare vetro-vetro regolabile.

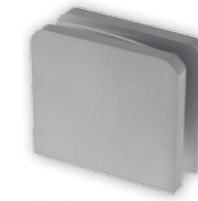
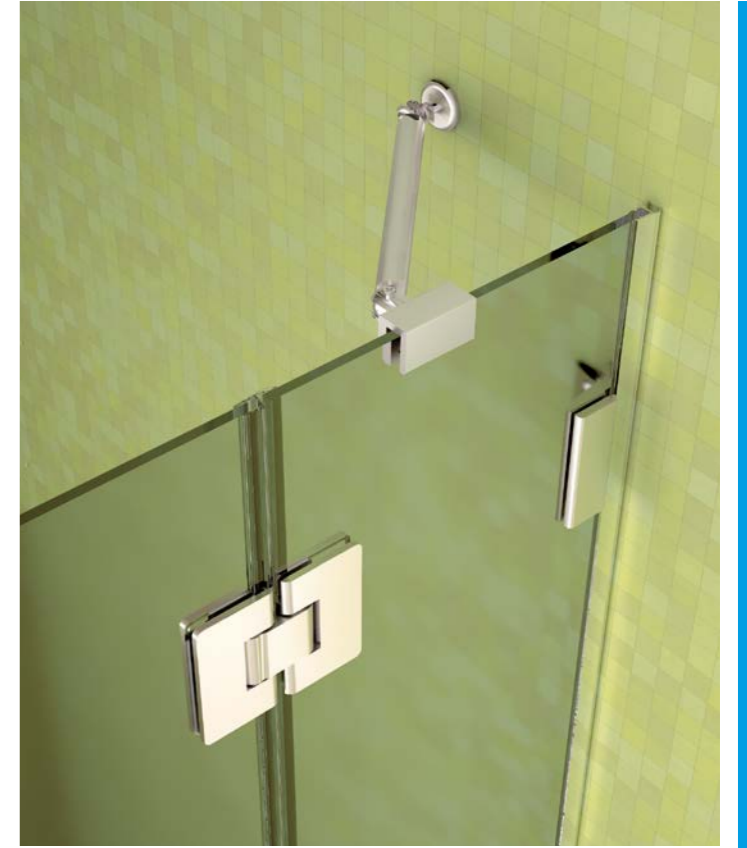

art. 4500

- Duş kabinler için küçük kelepçe.
- Small clamp for shower boxes.
- Morsetto piccolo per box doccia.



art. 4502

- Duş kabinler için kelepçe.
- Clamp for shower boxes.
- Morsetto per box doccia.

0° +90° -90°

**GİZLİ VİDA DETAYLI AYARLANABİLİR YAYLI MENTEŞE , CAM TUTUCU VE KOLLAR**  
**CONCEALED SCREW DETAILED ADJUSTABLE HINGE,CORNER ,HANDLES-CERNIERE ANGOLARI MANIGLIONI**

**art. 855W1R**

- Ayarlanabilir yaylı duş menteşesi. Asimetrik bağlantı plakalı olup vidaları gizleyen kapaklar mevcuttur. 0° 'de durur.
- Adjustable clicking hinge for shower with offset fixing wing and with cover for screws. Stop at 0°.
- Cerniera a scatto regolabile , aletta spostata vetro-muro, con copertine copriviti. Apertura +90° - 90° e posizione di stop a 0°.



**art. 855W5R**

- Ayarlanabilir cam cama yaylı duş menteşesi. Vidaları gizleyen kapaklar mevcuttur. 0° 'de durur.
- Adjustable glass to glass clicking hinge for shower with cover for screws. Stop at 0°.
- Cerniera a scatto regolabile , vetro-vetro 180°, con copertine copriviti. Apertura +90° - 90° e posizione di stop a 0°.

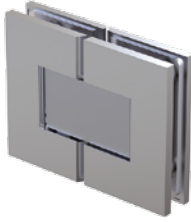

**art. 445W10**

- Cam duvar bağlantı aksesuarı. Vidaları gizleyen kapakları mevcuttur.
- Angular fitting wall to glass , with covers for screws.
- Angolare muro-vetro , con copertina copriviti.

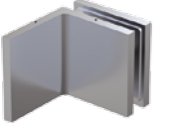

**art. 446W50**

- Cam cama 90° bağlantı aksesuarı. Vidaları gizleyen kapakları mevcuttur.
- Angular fitting glass to glass 90° , with covers for screws.
- Angolare vetro-vetro 90°, con copertina copriviti.



**art. 502W30**

- Kare kesitli kol çifti. Aks mesafesi 254mm.
- Pair of handles, square section. Centre distance 254mm.
- Coppia maniglioni dritti, sezione quadra. Interasse 254mm.



**art. 504W30**

- Kare kesitli H kol çifti. Aks mesafesi 254mm.
- Pair of handles, flat handgrip. Centre distance 254mm.
- Coppia maniglioni dritti, impugnatura piatta. Interasse 254mm.

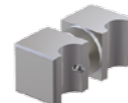

**art. 506W30**

- Topuz çifti.
- Pair of knobs.
- Coppia pomoli.



## DUŞ KABINI İÇİN HİDROLİK SİSTEM HYDRAULIC SYSTEM FOR SHOWER BOX - OLEODINAMICA SISTEMA PER BOX DOCCIA



### art. D05E30N

- İki duvar arası Slash Set. Tek kanatlı. 90°de durur.
- Slash niche set wall-wall. One door. Stop at 90°.
- Kit Slash per box doccia in nicchia a tutta larghezza. Stop +90°.



### art. D05E72N

- Duvar cam duş teknesi için Slash Set. Bir kanat bir sabit. 90°de durur.
- Set Slash for shower tray wall-glass. One door and one fixed glass. Stop at +90°.
- Kit Slash per box doccia con 1 spalla in vetro. Con vetro fisso frontale. Stop a +90°.



### art. D05E32N

- İki duvar arası Slash Set. Bir kanat bir sabit. 90°de durur.
- Slash niche set wall-wall. 1 door and fixed glass. Stop at +90°.
- Kit Slash per box doccia in nicchia con vetro fisso frontale. Stop a +90°.



### art. D05E60N

- Cam cama duş teknesi için Slash Set. Tek kanatlı. 90°de durur.
- Slash set for shower tray glass-glass . One door. Stop at +90°.
- Kit Slash per box doccia con 2 spalle in vetro. Stop a +90°.



### art. D05E62N

- Cam cama duş teknesi için Slash Set. Bir kanat bir sabit. 90°de durur.
- Slash set for shower tray glass-glass. 1 door and fixed glass. Stop at +90°.
- Kit Slash per box doccia con 2 spalle in vetro. Con vetro fisso frontale. Stop a +90°.



### art. D05E70N

- Duvar cam duş teknesi için Slash Set. Tek kanatlı. 90°de durur.
- Set Slash for shower tray wall-glass. One door. Stop at +90°.
- Kit Slash per box doccia con 1 spalla in vetro. Stop a +90°.



# Topuz ve Kapı Kolları

KNOBS and HANDLES - POMOLI e MANIGLIE

# Gergi Barları ve Havluluklar

BARS FOR FIXED PANEL and TOWEL BAR - FERMAVETRO e PORTASALVIETTE



**art. 5400**

- Kapı kulpu çifti. Çap 25mm.
- Pair of door knobs. Diameter 25mm.
- Coppia pomoli. Diametro 25mm.

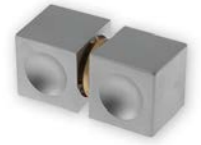

**art. 5Q12**

- Kapı kulpu çifti. 20x20mm.
- Pair of knobs 20x20mm.
- Coppia pomoli 20x20mm.



**art. 5401**

- Kapı topuzu çifti. Çap 48mm.
- Pair of door knobs. Diameter 48mm.
- Coppia pomoli. Diametro 48mm.



**art. 5410**

- Kapı topuzu çifti. Çap 48mm.
- Pair of door knobs. Diameter 48mm.
- Coppia pomoli. Diametro 48mm.



**art. 5A00**

- Ala sistem kapı kulpu çifti.
- Ala system knobs.
- Coppia pomoli Ala system.



**art. 515E30**

- Kol çifti.
- Pair of handles.
- Coppia pomoli.



**art. 5C00**

- Kapı kolu çifti merkez uzaklığı 170mm.
- Paslanmaz çelik.
- Handle Centre distance 170mm.
- Stainless steel.
- Maniglia interasse 170mm. Acciaio inox.



**art. 5H01**

- Kapı kolu çifti. Merkez uzaklığı 192mm.
- Paslanmaz çelik.
- Pair of handles. Centre distance 192mm. Stainless steel.
- Coppia maniglioni dritti. Interasse 192mm. Acciaio inox.



**art. 5H03**

- Kapı kolu çifti. Merkez uzaklığı 250mm.
- Paslanmaz çelik.
- Pair of handles. Centre distance 250mm. Stainless steel.
- Coppia maniglioni dritti. Interasse 250mm. Acciaio inox.



**art. 4Q12, 4Q13**

- Hip-q cam duvar tutucular.
- Hip-q wall to glass clamp.
- Morsetto Hip-q vetro/muro.



**art. 4Q20**

- Hip-q cam cama 90° tutucu.
- Hip-q glass to glass clamp
- Sistema di fissaggio Hip-q sezione quadra 2 punti fissi vetro



**art. 5F01T**

- 5F01 ve 5F04 gergi barları için aksesuar.
- Accessory for stabilising bars 5F01 and 5F04.
- Accessorio per barre fermavetro 5F01 e 5F04.



**art. 5F01**

- Sabit paneller için duvardan cama gergi barı.
- Wall to glass bar for fixed panels.
- Barra fermavetro muro-vetro fisso.



**art. 5F04**

- 2 sabit panel için cam-cama gergi barı.
- Glass to glass bar for 2 fixed panels.
- Barra fermavetro vetro-vetro per due fissi.



**art. 5F20**

- Sabit paneller için duvardan cama gergi barı. Kare kesit. U=350mm.
- Wall to glass bar for fixed panels. Square section. L=350mm.
- Barra fermavetro muro-vetro fisso. Sezione quadra. L=350mm.



**art. 5F22**

- Sabit paneller için duvardan cama gergi barı. Kare kesit. U=1000mm.
- Wall to glass bar for fixed panels. Square section. L=1000mm.
- Barra fermavetro muro-vetro fisso. Sezione quadra. L=1000mm.



**art. 5F08**

- Sabit paneller için 45° duvardan cama gergi barı.
- Wall to glass bar 45° for fixed panels.
- Barra fermavetro 45° muro-vetro fisso.



**art. 5F10**

- Uzun sabit paneller için 45° duvardan cama gergi barı.
- Wall to glass bar 45° for long fixed panels.
- Barra fermavetro 45° muro-vetro fisso lungo.



# Antibakteriyel Fitiller ve Profiller

ANTIBACTERIAL SEALS and PROFILES - GUARNIZIONI

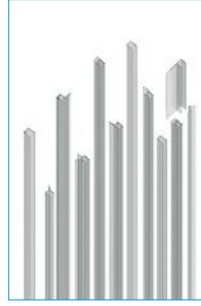

## art. VARI

- Antibakteriyel sararmaya karşı dayanıklı duş fitilleri. L:2200mm
- Antibacterial shower gasket, resistant against getting yellowish. L: 2200mm.
- Guarnizioni L: 2200mm

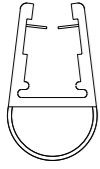

## 8PT8-10

- Duvardan cama fitil. L=2200mm. Cam kalınlığı : 6 - 8 mm.
- Glass to wall seal. L=2200mm. Glass thickness : 6 - 8 mm.

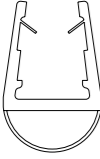

## 8PT1-10

- Duvardan cama fitil. L=2500mm. Cam kalınlığı : 8 - 10 mm.
- Glass to wall seal. L=2500mm. Glass thickness : 8 - 10 mm.



## 8PT1-20

- Yönlendirici fitil. L=2500mm. Cam kalınlığı : 10 mm.
- Diverting seal. L=2500mm. Glass thickness : 10 mm.

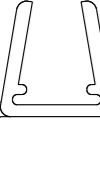

## 8PT8-20

- Yönlendirici fitil. L=2200mm. Cam kalınlığı : 6 - 8 mm.
- Diverting seal. L=2200mm. Glass thickness : 6 - 8 mm.

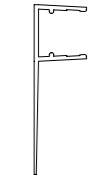

## 8PT8-25

- Yönlendirici fitil. L=2200mm. Cam kalınlığı : 8 - 10 mm.
- Diverting seal. L=2200mm. Glass thickness : 8 - 10 mm.

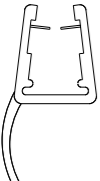

## 8PT8-30

- Yönlendirici fitil 180°. L=2200mm. Cam kalınlığı : 6 - 8 mm.
- Diverting seal 180°. L=2200mm. Glass thickness : 6 - 8 mm.

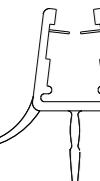

## 8PT35-C

- Bombeli camlar için çift yönlendirici fitil. R = 540 L = 490mm. Cam kalınlığı: 6-8mm
- Profil for curved glass with double deflector R = 540 L = 490mm. Glass thickness : 6 - 8mm.

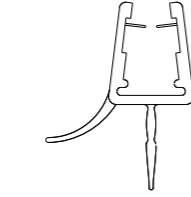

## 8PT8-35

- Çift yönlendirici fitil. L=2200mm. Cam kalınlığı : 6 - 8 mm.
- Double diverting seal. L=2200mm. Glass thickness : 6 - 8 mm..

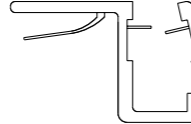

## 8PT8-40

- 90° duran fitil. L=2200mm. Cam kalınlığı : 6 - 8 mm.
- Stop seal 90°. L=2200mm. Glass thickness : 6 - 8 mm.

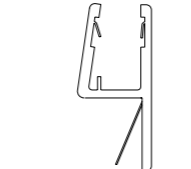

## 8PT8-45

- 180° duran fitil. L=2200mm. Cam kalınlığı : 6 - 8 mm.
- Stop seal 180°. L=2200mm. Glass thickness : 6 - 8 mm.

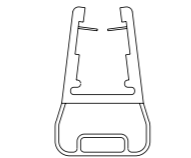

## 8PT8-50

- 180° mıknatıslı fitil. L=2200mm. Cam kalınlığı : 6 - 8 mm.
- Magnetic seal 180°. L=2200mm. Glass thickness : 6 - 8 mm.

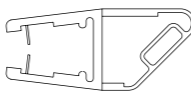

## 8PT8-60/61

- 90° köşe mıknatıslı fitil. Kuzey-Güney. L=2200mm. Cam kalınlığı : 6 - 8 mm.
- Magnetic seal for 90° corner. North-South. L=2200mm. Glass thickness : 6 - 8 mm.

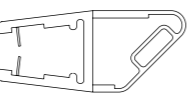

## 8PT1-60/61

- 90° köşe mıknatıslı fitil. Kuzey-Güney. L=2500mm. Cam kalınlığı : 8 - 10 mm.
- Magnetic seal for 90° corner. North-South. L=2500mm. Glass thickness : 8 - 10 mm.

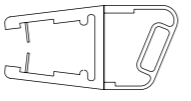

## 8PT8-70/71

- 135° köşe mıknatıslı fitil. Kuzey-Güney. L=2200mm. Cam kalınlığı : 6 - 8 mm.
- Magnetic seal for 135° corner. North-South. L=2200mm. Glass thickness : 6 - 8 mm.

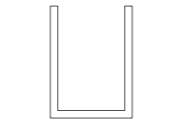

## 8P06 / 8P08 / 8P10

- Paslanmaz çelik U profil. L=2200mm. Renkler : 31 veya 32. Cam kalınlığı : 6 - 8 - 10 mm.
- Stainless steel U shaped pipe. L=2200mm. Colors 31 or 32. Glass thickness : 6 - 8 - 10 mm.



## 8P11-32

- Paslanmaz çelik profil. L = 2200mm. Mıknatıslı fitil ile birlikte kullanılır.
- Stainless steel profile. L= 2200mm. Use together with magnetic seal



## İÇ KAPI MENTEŞELERİ

Hinges For Inner Doors  
Cerniere per Porte Interne

## Biloba 0° +90° -90°

HİDROLİK MENTEŞELER  
HYDRAULIC HINGES - CERNIERE OLEODINAMICHE



art. 8010

- Kapanma hızı ayarlanabilir hidrolik menteşe.
- Hydraulic hinge with adjustment of the closing speed.
- Cerniera oleodinamica con regolazione della velocità di chiusura.



art. 8011

- Kapanma hızı ayarlanabilir hidrolik menteşe. (tek yönlü bağlantı plakası ile).
- Hydraulic hinge (with offset fixing wing) with adjustment of the closing speed.
- Cerniera oleodinamica (con aletta spostata) con regolazione della velocità di chiusura.



art. 8015

- Kapı kapanma hızı ayarlanabilir hidrolik menteşe. (cam-cama).
- Hydraulic hinge (glass to glass) with adjustment of the closing speed of the door.
- Cerniera oleodinamica (vetro-vetro) con regolazione delle velocità di chiusura dell'anta.



## Biloba 0° +90°

HİDROLİK MENTEŞE  
HYDRAULIC HINGE - CERNIERA OLEODINAMICA



art. 8060

- Binli kapı için kapanma hızı ayarlanabilir hidrolik menteşe.
- Hydraulic hinge with adjustment of the closing speed of door with stop.
- Cerniera oleodinamica con regolazione delle velocità di chiusura dell'anta per porte in battuta.



## Unica 0° +90° -90°

HİDROLİK MENTEŞELER  
HYDRAULIC HINGES - CERNIERE OLEODINAMICHE



art. 101E10NF

- Kapanma hızı ayarlanabilir hidrolik menteşe. Genel kapanış ve son vuruş olmak üzere 2 hız ayarı vardır.
- Hydraulic hinge with adjustment of the closing speed of the door.
- Cerniera oleodinamica con regolazione della velocità di chiusura dell'anta.

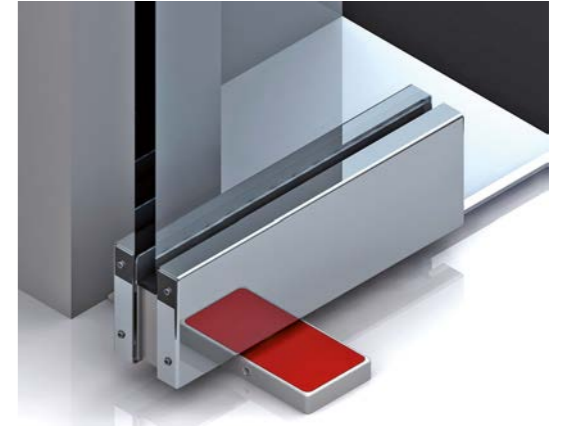

RÜZGAR FRENİ YOK - NO ANTI-WIND BRAKE - NON DOTATA DI FRENO ANTIVENTO



# Biloba EVO SOL



## Evo Sol 180°

HİDROLİK MENTEŞELER  
HYDRAULIC HINGES - CERNIERE OLEODINAMICHE



### art. 835E10SOL

- Binili kapılar için serbest menteşe. 835E10-835E11 ile birlikte kullanılır.
- Free hinge wall-glass for doors with stop. To be matched with 835E10-835E11.
- Cerniera libera vetro-muro per porte in battuta. Da abbinare a 835E10-835E11.

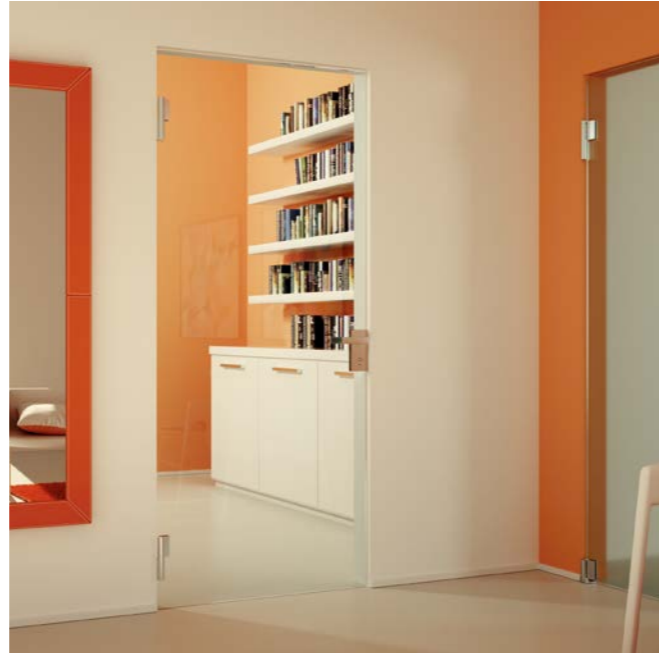

### art. 835E50SOL

- Binili kapılar için cam cama serbest menteşe. 835E50-835E51 ile birlikte kullanılır.
- Free hinge glass to glass for doors with stop. To be matched with 835E50-835E51.
- Cerniera libera vetro-vetro per porte in battuta. Da abbinare a 835E50-835E51.



### art. 836E10

- Binili kapılar için serbest menteşe. 835E10-835E11 ile birlikte kullanılır. Zemine monte.
- Free bottom pivot hinge for doors with stop. To be matched with 835E10-835E11.
- Cerniera libera a terra per porte in battuta. Da abbinare a 835E10-835E11.

# Biloba UNICA SLIM Hidrolik Menteşeler

## Unica Slim 0° +90° -90°

HİDROLİK MENTEŞELER  
HYDRAULIC HINGES - CERNIERE OLEODINAMICHE



### art. 106E10

- Hidrolik alt menteşe. Sıfır noktası ayarı.
- Hydraulic bottom hinge. Adjustment of zero point.
- Cerniera oleodinamica. Regolazione allineamento.



### art. 106E20/27

- Üst menteşe ve tavan bağlantı plakası.
- Top hinge and ceiling fixation plate.
- Cerniera superiore per Unica Slim con piletta.





# Biloba Evo Frame



## Evo Frame 180°

HİDROLİK MENTEŞE - AHŞAP VE ÇERÇEVELİ KAPILAR İÇİN.  
HYDRAULIC HINGES FOR WOODEN DOORS AND DOOR  
LEAF WITH FRAME - CERNIERE OLEODINAMICHE



### art. 835EBMC40

- Binili ahşap kapılar ve çerçevesiz cam kapılar için hidrolik menteşe. Ayarlanabilen kapanış hızı ve sürekli fren kontrolü. Kapı 180° açılır. +90° ve +180° de durur.
- Hydraulic hinge for wooden doors and door leaf with frame with stop. Adjustable closing speed and constant braking control. The door opens up to 180°. Stop at +90° and 180°.
- Cerniera oleodinamica con velocità di chiusura regolabile e controllo costante di frenatura; permette un'apertura della porta fino a 180°.



### art. 835EBMC40SOL

- Binili ahşap kapılar ve çerçevesiz cam kapılar için menteşe. 835EBMC40 ile birlikte kullanılır.
- Hinge for wooden doors and door leaf with frame with stop. To be used with 835EBMC40.
- Cerniera per porte in legno con fermo. Da utilizzare con 835EBMC40.

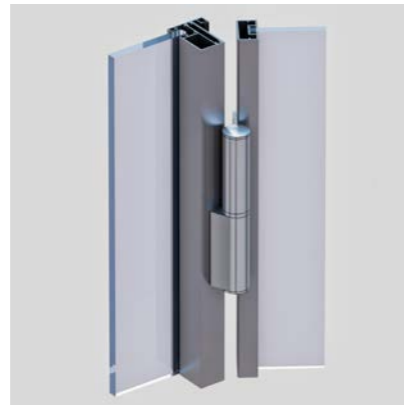

# 861 Seri - Series

# 863 Seri - Series

0° +90° -90°

## OTOMATİK MENTEŞELER AUTOMATIC HINGES - CERNIERE AUTOMATICHE



**art. 8609**

- Tek yönlü bağlantı plakası ile otomatik menteşe.
- Automatic hinge with offset fixing wing.
- Cerniera automatica con aletta spostata.



**art. 8610**

- Otomatik menteşe.
- Automatic hinge.
- Cerniera automatica.



**art. 8611**

- Cam-cama 180° otomatik menteşe.
- Automatic hinge glass to glass 180°.
- Cerniera automatica vetro-vetro 180°.

0° +90° -90°

## OTOMATİK MENTEŞELER AUTOMATIC HINGES - CERNIERE AUTOMATICHE



**art. 8630**

- Otomatik menteşe.
- Automatic hinge.
- Cerniera automatica.



**art. 8631**

- Tek yönlü bağlantı plakası ile otomatik menteşe.
- Automatic hinge with offset fixing wing.
- Cerniera automatica con aletta spostata.



**art. 8635**

- Cam-cama 180° otomatik menteşe.
- Automatic hinge glass to glass 180°.
- Cerniera automatica vetro-vetro 180°.



# 870 Seri - Series

# 865 Seri - Series

0° +90° -90°

## YAYLI MENTEŞELER CLICKING HINGES - CERNIERE A SCATTO



**art. 8700**

- Yaylı menteşe.
- Clicking hinge.
- Cerniera a scatto.



**art. 8701**

- Tek yönlü bağlantı plakası ile yaylı menteşe.
- Clicking hinge with offset fixing wing.
- Cerniera a scatto con aletta spostata.



**art. 8705**

- Cam-cama 180° yaylı menteşe.
- Clicking hinge glass to glass 180°.
- Cerniera a scatto vetro-vetro 180°.

## YAN MENTEŞELER SIDE HINGES - CERNIERE LATERALI



**art. 8650**

- Dar kapı kasaları için yan menteşe.
- Side hinge for narrow door-jambs.
- Cerniera laterale per stipite stretto.



**art. 8652**

- Cam-cama 180° yan menteşe.
- Double side hinge glass to glass. 180°
- Cerniera doppia vetro-vetro. 180°



**art. 8653**

- Dar kapı kasaları için yan menteşe.
- Side hinge for narrow door-jambs.
- Cerniera laterale per stipite stretto.

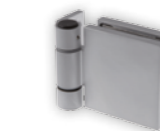

**art. 8654**

- Dar kapı kasaları için küçük yan menteşe.
- Side hinge for narrow door-jambs.
- Cerniera laterale per stipite stretto.



**art. 8655**

- Cam-cama 180° küçük yan menteşe.
- Small side hinge glass to glass. 180°.
- Cerniera laterale piccola vetro-vetro. 180°.



# 866 Seri - Series

## YAN MENTEŞELER - SIDE HINGES - CERNIERE LATERALI



**art. 8662**

- Cam-cama 180° daireseel yan çift taraflı menteşe.
- Rounded double side hinge glass to glass. 180°.
- Cerniera tonda doppia vetro-vetro. 180°.



**art. 8667**

- 40 ila 50mm arasındaki kapı kasaları için yan menteşe.
- Side hinge for door-jambs of 40 to 50mm.
- Cerniera laterale per stipiti da 40 a 50mm.



**art. 8663**

- Dar kapı kasaları için yan menteşe.
- Side hinge for narrow door jambs.
- Cerniera laterale tonda per stipite stretto.



**art. 8S10**

- 45mm kapı kasaları için bağlantı plakalı yan menteşe.
- Side hinge for door-jamb of 45mm with fixing plate.
- Cerniera laterale stipite da 45mm con piastrina di fissaggio.



**art. 8664**

- 30 ila 42mm arasındaki kapı kasaları için daireseel yan menteşe.
- Rounded side hinge for door-jambs of 30 to 42mm.
- Cerniera laterale tonda per stipiti da 30 a 42mm.



**art. 8S11**

- Ahşap kapılar için menteşe.
- Hinge for wooden doors.
- Cerniera per porte in legno.



**art. 8665**

- 30 ila 42mm arasındaki kapı kasaları için yan menteşe.
- Side hinge for door-jambs of 30 to 42mm.
- Cerniera laterale per stipiti da 30 a 42mm.



**art. 8674**

- 30-42 mm arasındaki kapı kasaları için yan menteşe.
- Side hinge for door-jambs of 30 to 42mm.
- Cerniera laterale per stipiti da 30 a 42mm.



**art. 8666**

- 40 ila 50mm arasındaki kapı kasaları için daireseel yan menteşe.
- Rounded side hinge for door-jambs of 40 to 50mm.
- Cerniera laterale tonda per stipiti da 40 a 50mm.



**art. 8810**

- 30-42 mm arasındaki kapı kasaları için Flexa seri yan menteşe.
- Side hinge for door-jambs of 30 to 42mm.
- Cerniera laterale per stipiti da 30 a 42mm.

# 8PB7-15 ve 8PB7-10

## KAPILAR İÇİN ÇİFT TARAFLI YAPIŞKANLI SİSTEMLER - ADHESIVE SEALS FOR DOORS

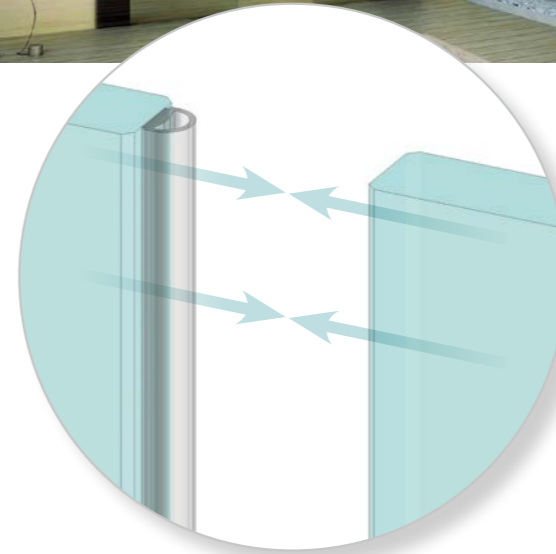

PATENTED ©  
**8PB7-10**

**Balon Fitol - Bumper balloon seal**



**8PB7-10**

Yapışkan bantlı patentli balon fitil V.H.B.3M Patented profile with transparent adhesive V.H.B 3M®. Profilo brevettato con nastro trasparente V.H.B 3M®.

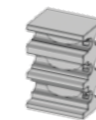

**A-8PB7-10**

8PB7-10 fitili için aplikatör. Template for the seal 8PB7-10. Applicatore profilo 8PB7-10.

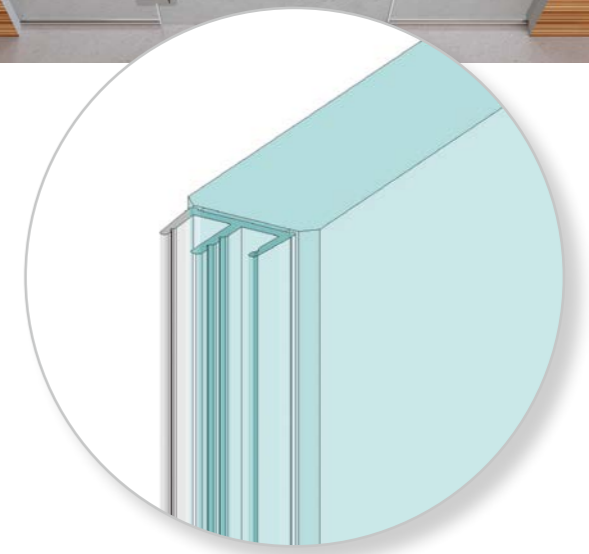

PATENTED ©  
**8PB7-15**

**3 Tırnaklı Fitol - 3 lips seal**

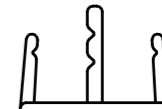

**8PB7-15**

Yapışkan bantlı patentli balon fitil V.H.B.3M Patented profile with transparent adhesive V.H.B 3M®. Profilo brevettato con nastro trasparente V.H.B 3M®.

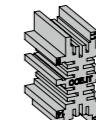

**A-8PB7-15**

8PB7-15 fitili için aplikatör. Template for the seal 8PB7-15. Applicatore profilo 8PB7-15.



## CAM BÖLME PROFİL VE AKSESUARLARI

Glass Wall Profile and Accessories  
Partizioni e Sistema Profili



**art. 4NB1**

- Paslanmaz çelik gömme vida ile somun. 8-15mm cam.
- Flat boss with stainless steel countersunk screw. 8-15mm glass.
- Borchia inox per vetro. 8-15mm filo vetro.



**art. 4NB2**

- Paslanmaz çelik gömme vida ile somun. 16-23mm cam.
- Flat boss with stainless steel countersunk screw. 16-23mm glass.
- Borchia inox per vetro. 16-23mm filo vetro.



**art. 4NB3**

- Paslanmaz çelik gömme vida ile somun. 24-30mm cam.
- Flat boss with stainless steel countersunk screw. 24-30mm glass.
- Borchia inox per vetro. 24-30mm filo vetro.



**art. 4NB1a**

- Paslanmaz çelik gömme vida ile somun. 8-15mm cam.
- Flat boss with stainless steel countersunk screw. 8-15mm glass.
- Borchia inox per vetro. 8-15mm filo vetro.



**art. 4NB2a**

- Paslanmaz çelik gömme vida ile somun. 16-23mm cam.
- Flat boss with stainless steel countersunk screw. 16-23mm glass.
- Borchia inox per vetro. 16-23mm filo vetro.



**art. 4NB3a**

- Paslanmaz çelik gömme vida ile somun. 24-30mm cam.
- Flat boss with stainless steel countersunk screw. 24-30mm glass.
- Borchia inox per vetro. 24-30mm filo vetro.



**art. 4NB1b**

- Paslanmaz çelik gömme vida ile somun. 8-15mm cam.
- Glass wire eccentric flange with 8-15mm M8x22 screw for glass.
- Borchia inox per vetro. 8-15mm filo vetro. Eccentrica.



**art. 4NB2b**

- Paslanmaz çelik gömme vida ile somun. 16-23mm cam.
- Glass wire eccentric flange with 16-23mm M8x22 screw for glass.
- Borchia inox per vetro. 16-23mm filo vetro. Eccentrica.



**art. 4NB3b**

- Paslanmaz çelik gömme vida ile somun 24-30mm M8x22
- Glass wire eccentric flange with 24-30mm M8x22 screw for glass.
- Borchia inox per vetro. 24-30mm filo vetro. Eccentrica.



**art. 4NB5**

- 8-16mm cam için harici somun.
- External stud for 8-16mm glass.
- Borchia esterna per vetro 8-16mm.



**art. PCC14A/3 - PCC14/3 - PCC18/3**

- 8-10-12mm cam için 3 farklı ekstra şeffaf polikarbon derz çıtaları. 2 yollu
- Extra transparent polycarbonate profile for 8-10-12mm glass.
- Profilo fermavetro 2 vie in polycarbonato con bi-adesivo.

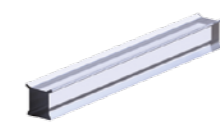

**art. PCC13/3**

- 10-10,38mm cam için ekstra şeffaf polikarbon derz çıtası. 3 yollu birleşim
- Extra transparent polycarbonate profile for 8-10mm glass. 3 ways.
- Profilo fermavetro 3 vie in polycarbonato con bi-adesivo.

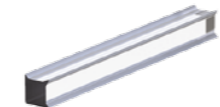

**art. PCC12/3**

- 10-10,38mm cam için ekstra şeffaf polikarbon derz çıtası. 90° köşe birleşim
- Extra transparent polycarbonate profile for 8-10mm glass. 90° corner.
- Profilo fermavetro 2 vie 90° in polycarbonato con bi-adesivo.

# Sabitleme Kelepçeleri

FIXED CLAMPS - MORSETTI



**art. A70**

- Sabit cam paneller için kelepçe.
- Clamp for fixed glass panels.
- Morsetto per vetri fissi.



**art. 1710**

- Sabit cam paneller için kelepçe.
- Clamp for fixed glass panels.
- Morsetto per vetri fissi.



**art. 4040**

- 6 ila 15 mm arası sıkma kolu. Camda delik yoktur.
- Lever clamp for 6 to 15mm. Without notch in the glass.
- Morsetto a leva per spessori da 6 a 15mm senza tacca nel vetro.



**art. 4041**

- 6 ila 15 mm arası sıkma kolu. Camda delik yoktur. Yançap isteğe bağlıdır.
- Lever clamp for 6 to 15mm. Without notch in the glass. Radius on request.
- Morsetto a leva per spessori da 6 a 15mm senza tacca nel vetro. Raggiatura a richiesta.



**art. 490W10**

- 55x55 mm kare cam tutucu . 316 kalite paslanmaz çelik.
- Squared clamp 55x55mm. In stainless steel Aisi 316.
- Morsetto quadro 55x55mm. In acciaio inox Aisi 316.



**art. 493W10**

- 55x70 mm dikdörtgen cam tutucu . 316 kalite paslanmaz çelik.
- Rectangular clamp 55x70mm. In stainless steel Aisi 316.
- Morsetto rettangolare 55x70mm. In acciaio inox Aisi 316.



**art. 496W10**

- 45x53 mm dairesel cam tutucu . 316 kalite paslanmaz çelik.
- Rounded clamp 45x53mm. In stainless steel Aisi 316.
- Morsetto tondo 45x63mm. In acciaio inox Aisi 316.



**art. 499W10**

- 60x70 mm dikdörtgen cam tutucu 316 kalite paslanmaz çelik.
- Squared clamp 60x70. In stainless steel Aisi 316.
- Morsetto quadro 60x70. In acciaio inox Aisi 316.

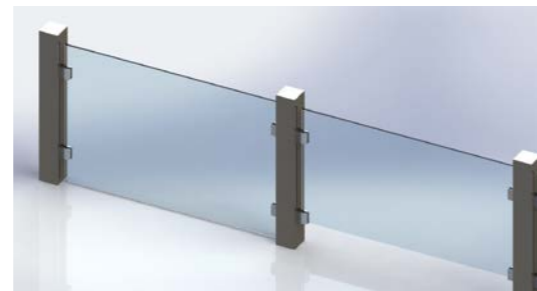

# Cam Tutucular

SPACERS - DISTANZIALI



**art. 4360**

- Korkuluklar için alüminyum cam tutucu.
- Aluminium spacer for railings.
- Distanziale per parapetti in alluminio.



**art. 4360i**

- Korkuluklar için paslanmaz çelik cam tutucu.
- Stainless-steel spacer for railings.
- Distanziale per parapetti in acciaio inox.



**art. 430W20**

- Paslanmaz çelik antishock cam tutucu. Yüksek strese maruz kalan korkuluklar için özel iç mekanizması.
- Spacer Antishock made of stainless steel, with internal damping system. Suitable for railing subject to high stress.
- Distanziale Antishock in acciaio inox, con sistema interno di ammortizzazione degli urti. Ideale per parapetti soggetti a forti sollecitazioni.



**art. A00W**

- Cam korkuluklar için paslanmaz çelik küpeşte. 90° ve 180° birleşimleri ve montaj cantaları mevcuttur.
- Handrail made of satin Stainless-steel for glass railings. The range includes 90° and 180° connectors, all equipped with protections and rubber inserts for installation purposes.
- Corrimano in acciaio inox satinato per parapetti in vetro. La gamma comprende anche connettori di 90° e 180°, tutti forniti di protezioni e inserti in gomma per l'installazione.



# Poise sistem - system

## CAM BÖLME SİSTEMLERİ GLASS WALL SYSTEMS - PARETI CONTINUE



POISE, aralıksız cam duvarların hızla yapılmasına ve kolayca uygulanmasına imkan veren modüler bir profil sistemidir. Profillerde destek aletleri ve kısaç bulunur ve 8 ila 10 mm kalınlıktaki camları destekler. Sabit cam profil ebatları 45x55 mm dir. Özel sürgüler ve mafsalları sayesinde, şaşırtıcı bir süreklilik etkisiyle farklı alanlar yaratabilirsiniz.

POISE is a modular profile system that allows the creation of continuous glass windows quickly and easily installable. The profiles contain support devices and pliers and hold glass from 8 to 10 mm thick. Fixed glass profile dimensions are 45x55 mm. Thanks to special seals and joints you can create different spaces with surprising continuity effects.

POISE è un sistema modulare di profili che consente la realizzazione di vetrate continue di rapida e semplice installazione. I profili contengono dispositivi di sostegno e pinze e accolgono vetri con spessori da 8 a 10 mm. Grazie a snodi e a speciali guarnizioni si possono creare molteplici spazi con sorprendenti effetti di continuità.

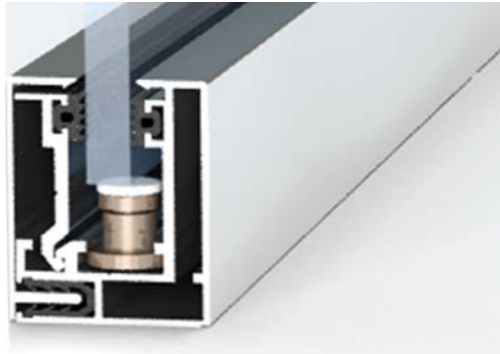

# Crystalline sistem - system

## CAM BÖLME SİSTEMLERİ PROFILE FOR GLASS FIXING - PROFILO FERMAVETRO

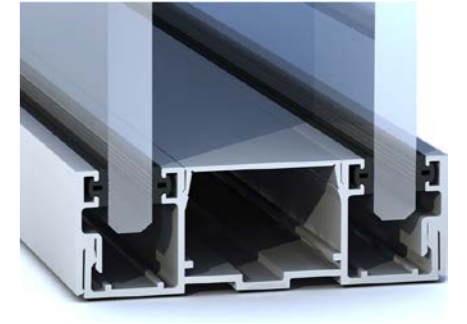

Cam cama bölme panel sistemleri için tasarlanmış, eloksal yüzey bitişli yeni alüminyum profil dizaynıdır. Gün ışığından yararlanmak ve bölme oluşturmak istenilen ev ve ofis ortamlarında rahatlıkla kullanılabilir. Çift camlı ve tek camlı olmak üzere iki alternatif mevcuttur. Tek camlı sistemin sabit cam profili 25x30 mm ebatlarında olup, 8-10 mm cam kalınlıkları ile kullanılabilir. Çift camlı sistemin sabit cam profili 90x30mm ebatlarında olup 6-12,76mm kalınlığındaki camlar için uygundur. Ürün 6 m boyunda, iyi bir kalite-fiyat oranı ile satışa sunulmuştur.

Profile in anodized alu. with click closing, which allows to create frames for continuous glass tempered panels. There are 2 alternatives as single and double glass systems. Single glass system is available for 8-10mm glass. Double glass system is available for 6-12,76mm glass thickness. The conduit is available in lengths of 6 meters as per a good quality-price ratio.

Profilo in alluminio anodizzato con chiusura a scatto, che consente di creare cornici essenziali per pareti continue in vetro temperato. La canalina fermavetro in soli 23 mm di spessore consente di installare vetri da 8 fino a 10 mm, 6-12,76 mm. Il formato e il design minimale favoriscono la posa di pareti divisorie in ogni ambiente e in tempi brevi grazie alla veloce e pratica installazione. La canalina è disponibile in lunghezze di 6 metri in un ottimo rapporto qualità prezzo.



# Kapı Kasaları ve Kablo Kanalı

Door Frames and Cable Channel

## AYARLANABİLİR KAPI KASALARI VE KAPI PROFİLLERİ ADJUSTABLE DOOR PROFILES - PROFILI PER PORTE REGOLABILI



BM ayarlanabilir cam kapı profil sistemleri ihtiyaç duyduğunuz çözümleri estetikte birleştirerek size sunar. 105-215 mm ile 215-250 mm kalınlıkları arasındaki duvarlara uygulanabilir.

Ayarlanabilir kapı profilleri, tasarıma önem verilen mekanlarda, temperli cam kapılara zarif bir görünüm katan ideal ve lineer bir çözümdür. Eloksal alüminyumdan üretilen bu ürün 6000 mm uzunluğundaki boylar halinde satışa sunulmuştur. Colcom' un kapı menteşeleri ve kapı kilitleriyle kusursuz bir uyum içinde kullanılabilir.

120 mm kalınlığındaki alüminyum kablo kanalı profili 6000 mm uzunluğundaki boylar halinde satışa sunulmuş olup, camla çevrili mekanlar için işlevsel çözüm sunar.

BM adjustable glass door profile systems incorporates the aesthetics of solutions you need. Suitable for 105-215 mm and 215-250 mm wall thickness provides easy installation and functionality.

Adjustable door profile is the ideal and linear solution in order to create an elegant frame, high design by the entry with tempered glass doors. The profile is made off anodized Alu and is supplied with rods, the length is 6000mm. The design has been especially studied in order to include Colcom's hinges and locks; it is available.

120 mm cable channel is sold as 6000 mm profiles. Functional solution for spaces surrounded by glass.



## SÜRME SİSTEMLERİ

Sliding Systems  
Sistemi per Porte Scorrevoli



**SÜRME SET**  
**SLIDING SET - KIT SCORREVOLE**



Flo sistem sürme kapıları 100 kg taşıma kapasitesi ve ayarlanabilir freni sayesinde son kullanıcıya konfor sunuyor.

Flo system sliding system provides comfort to the user with its 100kg capacity and adjustable break.

Sistema scorrevole coordinato Flo design. Soluzione altamente flessibile, si sposa con sopraporta e sovrapporte in cristallo, muratura, legno e strutture metalliche.

**SÜRME SET**  
**SLIDING SET - KIT SCORREVOLE**



Kompakt sürme sistem yalnız 50mm yüksekliktedir. Kolay uygulama. Su terazisi ayarının yapılmasına olanak sağlar. Geliştirilmiş fren sistemi ayarlanabilir olup sistem fonksiyonel bir tasarıma sahiptir.

Compact sliding system only 50 mm high. Easy installation. Equipped with an innovative damping system which is adjustable and adjusts set-up bubble directly from the ground. Essential design.

Sistema scorrevole compatto di soli 50mm di altezza. Facile installazione. Munito di un innovativo sistema di ammortizzazione variabile e di regolazione di messa a bolla direttamente da terra. Design essenziale.



## SÜRME SET SLIDING SET - KIT SCORREVOLE



Küçük panelli sürme sistem. Basit ve zarif tasarımı 103 mm yüksekliktedir. Tek ve çift kanatlı olarak kullanılabilen sistemde duvar ve tavan montaj seçenekleri mevcuttur.

Sliding system with small sprandel panel. Simple and elegant in 103 mm high. The internal mechanism is extremely robust and reliable and supports wall or ceiling, from single to double door.

Sistema scorrevole con veletta dalle dimensioni ridotte. Soglio ed elegante in 103mm di altezza. Il meccanismo interno è particolarmente robusto e affidabile e supporta fissaggi a parete o a soffitto nelle varianti con anta singola o doppia.



## SÜRME SET SLIDING SET - KIT SCORREVOLE



Geliştirilen Slak sistemi aynı teknik ve uygulama özelliklerini korur fakat 50 mm yüksekliği ve cam tutma kısıcaçlarıyla tasarımı farklıdır.

Evolution of the Slak system of which it maintains the same technical and practical characteristics, very different design thanks to its 50 mm in height with glass-blocking pliers.

Evoluzione del sistema Slak di cui mantiene le stesse caratteristiche tecniche ed applicative, design molto differente grazie ai 50 mm di altezza con pinze fermavetro a vista.



## TELESKOPIK AÇILIR SÜRME SET TELESCOPIC OPENNING SET - KIT SCORREVOLE



2 yollu raya sahip kapı sistemi, 2 camın paralel olarak aynı yönde açılıp kapanmasını sağlar. 4 farklı versiyona sahip 103 mm yüksekliğe kadar küçültülmüş boyutlarının içerisinde duvar ve tavan uygulamaları için sağlam bir yapı barındırır. Büyük açıklıkları ikiye bölmek için ideal çözümdür.

Sliding system with 2-ways rail which allows the parallel drive sliding of 2 moving glazings for each side, both while opening and closing. The spandrel panel with reduced dimensions of 103 mm in height, holds a robust mechanism that bears wall and ceiling applications in 4 versions. Ideal solution to separate big spaces into two.

EvSistema scorrevole con binario a due vie che permette lo scorrimento parallelo a trascinamento, sia in apertura che in chiusura, di 2 ante mobili per parte. La veletta dalle dimensioni ridotte di 103 mm di altezza, racchiude un meccanismo robusto che supporta applicazioni a muro e a soffitto in quattro varianti. Soluzione ideale per chiudere grandi luci fra due ambienti.



## SLAK SÜRME SİSTEMLER İÇİN YUMUŞAK KAPANIŞ SOFT-CLOSE FOR SLAK SLIDING SYSTEMS - SOFT-CLOSE PER SISTEMI SLAK



SOFT-CLOSE sistemi SLAK , SLAK-2 ve SLAK-T ürünlerine istek üzerine takılabilen fren mekanizmasıdır. SOFT-CLOSE sistemi kapıyı kapanma noktasına hafifçe değinceye kadar yavaşça durdurur.

SOFT-CLOSE is a braking mechanism for amortized locking, applicable on demand to SLAK and SLAK-2 systems. SOFT-CLOSE blocks the door slowly until it gently touches the closing beat.

SOFT-CLOSE è un meccanismo frenante per chiusure ammortizzate, applicabile su richiesta ai sistemi SLAK e SLAK-2. Con SOFT-CLOSE l'anta viene frenata lentamente fino a toccare silenziosamente la battuta di chiusura.



# Fluido 70 ve 150 sistem - system

HANDLES for sliding doors - MANIGLIE per scorrevoli

## SÜRME SET SLIDING SET - KIT



Minusco'nun yeni geliştirdiği sürme sistemi. 3 farklı kapanış seçeneği sunuyor; Mekanik fren, Soft-close ve yeni geliştirilmiş Anti-shock. Kullanıcının ihtiyaçlarına göre seçilebileceği bu sistemler 8-10mm cam ile kullanılabilir.

70kg ve 150kg taşıma kapasiteli 2 versiyonu mevcut olup, 60mm mekanizma yüksekliği ile kompakt bir sistemdir.

Tavana, duvara ve cama montaj alternatifleriyle birlikte tavana gömme modeli de bulunmaktadır.

Sabit camı da sisteme dahil eden özel ray profili kullanılmaktadır.



# Kelepçe, Kilit ve Kollar sürme kapılar için

CLAMP, LOCK and HANDLES - PINZE, SERRATURE e MANIGLIE

## SÜRME KAPILAR İÇİN KELEPÇELER CLAMPS FOR SLIDING DOORS - PINZE PER SCORREVOLI



### art. B905

- Sürme kapılar için kelepçe.
- Clamp for sliding doors.
- Pinza per porta scorrevole.



### art. B92

- Sürme kapılar için kelepçe. 8 mm vida dişi (isteğe bağlı 10 mm).
- Clamp for sliding doors. 8mm thread (10mm on request).
- Pinza per porta scorrevole. Filetto 8mm (10mm a richiesta).



### art. B925

- Sürme kapılar için kelepçe.
- Clamp for sliding doors.
- Pinza per porta scorrevole.

## SÜRME KAPILAR İÇİN KELEPÇELER CLAMPS FOR SLIDING DOORS - PINZE PER SCORREVOLI



### art. B93

- Sürme kapılar için küçük tutamak 120 mm.
- Small handle for sliding doors 120 mm.
- Maniglia per porta scorrevole 120 mm.



### art. 5B01

- Sürme kapı yüzük tutamağı çapı 40mm.
- Sliding door ring diameter 40mm.
- Anello per porta scorrevole d. 40mm.



### art. 5B05

- Sürme kapılar için küçük tutamak 120 mm.
- Small handle for sliding doors 120 mm.
- Maniglia per porta scorrevole 120 mm.



### art. 5BN0

- Neuscorre tutamak 400 mm.
- Neuscorre handle 400 mm.
- Maniglia Neuscorre 400 mm.

## SÜRME KAPILAR İÇİN KİLİTLER LOCK FOR SLIDING DOORS - SERRATURE PER SCORREVOLI



### art. B94



### art. B95



### art. B96



### art. B97





## DIŞ Kapi Mentesheleri

Hinges For Outer Doors  
Cerniere Per Porte Esterne

## Evo 180°

### HİDROLİK MENTEŞE HYDRAULIC HINGE - CERNIERA OLEODINAMICA



**Olağanüstü ve devrim yaratan: İç ve dış mekânlarda kullanılmak üzere kapı kapatıcı entegre edilmiş yeni menteşe. Binili kapılar içindir.**

Ayarlanabilir kapanış hızı ve sürekli fren kontrolü içeren ilk menteşe. 180°'ye kadar açılır. Ayrıca 90°'den 0°'ye kadar otomatik kapanan versiyonu mevcuttur. 90°'den 180°'ye kadar serbest menteşedir. Şok absorbe edici özelliği ile kapı hızla çarpıldığı anda menteşenin çıkmasını engeller ve aşırı baskıya karşı içinde bulunan bölüm kırılmayı önler.

**Prodigious and revolutionary: it is the new hinge with integrated door closer for doors with stop both internal external**

The first hinge with adjustable closing and constant braking control, for all door opening angles up to 180°. Also available in the version with automatic closing from 90° to 0°. Free hinge from 90° to 180°. It prevents onhinging through a shock absorber and has an over-pressure device that avoids breaking in accidental shoving scenarios.

**Prodigiosa e rivoluzionaria: è la nuova cerniera con chiudiporta integrato per porte in battuta interne ed esterne.**

La prima cerniera con chiusura regolabile e controllo costante di frenatura, per tutte le angolazioni di apertura della porta fino a 180°. Disponibile anche nella versione con automatismo di chiusura da 90° ve 0°. Controllo costante di frenatura. Cerniera libera da 90° a 180°. Fornita di un ammortizzatore anti-scardinamento e dotata di un dispositivo di sovrappressione che evita rotture in caso di strattamento accidentale.



#### art. 835E 10 +90° ve +180°de durur

• Binili kapılar için cam-duvar hidrolik menteşe. Ayarlanabilir kapanış hızı ve sürekli fren kontrolü. Kapı 180°'ye kadar açılır.

• Hydraulic hinge glass to wall for doors with stop, with adjustable closing speed and constant braking control. The door opens up to 180°.

• Cerniera oleodinamica vetro-muro per porte in battuta, con velocità di chiusura regolabile e controllo costante di frenatura; permette un'apertura della porta fino a 180°.

#### art. 835E 11 +180°de durur

• Binili kapılar için cam-duvar hidrolik menteşe. Ayarlanabilir kapanış hızı ve sürekli fren kontrolü. Kapı 180°'ye kadar açılır.

• Hydraulic hinge glass to wall for doors with stop, with adjustable closing speed and constant braking control. The door opens up to 180°.

• Cerniera oleodinamica vetro-muro per porte in battuta, con velocità di chiusura regolabile e controllo costante di frenatura; permette un'apertura della porta fino a 180°.

#### art. 835E 50 +90° ve +180°de durur

• Binili kapılar için cam-cama hidrolik menteşe. Ayarlanabilir kapanış hızı ve sürekli fren kontrolü. Kapı 180°'ye kadar açılır.

• Hydraulic hinge glass to glass for doors with stop, with adjustable closing speed and constant braking control. The door opens up to 180°.

• Cerniera oleodinamica vetro-vetro per porte in battuta, con velocità di chiusura regolabile e controllo costante di frenatura; permette un'apertura della porta fino a 180°.

#### art. 835E 51 +180°de durur

• Binili kapılar için cam-cama hidrolik menteşe. Ayarlanabilir kapanış hızı ve sürekli fren kontrolü. Kapı 180°'ye kadar açılır.

• Hydraulic hinge glass to glass for doors with stop, with adjustable closing speed and constant braking control. The door opens up to 180°.

• Cerniera oleodinamica vetro-vetro per porte in battuta, con velocità di chiusura regolabile e controllo costante di frenatura; permette un'apertura della porta fino a 180°.



# Biloba EVO Hidrolik menteşeler



## Evo 180°

HİDROLİK MENTEŞE  
HYDRAULIC HINGE - CERNIERA OLEODINAMICA  
INDOOR & OUTDOOR

scan for video



Hidrolik kapı kapatıcıların evrimi ve sentezi niteliğinde olan yenilikçi EVO hidrolik menteşe , iç ve dış mekânlardaki kontrollü kapanış istenen cam kapılar için en ideal çözümü sunmaktadır. Evo Hidrolik menteşenin cam cama versiyonunun yanı sıra , cam duvar modeli de mevcut olup 1.000.000 kez açma kapama için test edilmiştir. Alman TUV sertifikasına sahip olan ürün , 120kg taşıma kapasitesine sahiptir.



# Biloba EVO Vela



## Hidrolik menteşeler

### Evo Vela

GİZLİ HİDROLİK MENTEŞE HIDDEN OILDYNAMIC HINGE  
CERNIERA CHIUDIORTA A SCOMPARSA

#### Gizli Hidrolik Menteşe. Binili alüminyum doğramalar için.

Yeni gizli hidrolik menteşe, binili alüminyum doğramalar içindir. Profilin içine tamamen gizlenen ilk Colcom menteşesidir. Kullanıcı talebine göre tüm projelere adapte olabilir. Biloba Evo seri menteşeler ile aynı özelliklere sahiptir. Ayarlanabilen bir hızla kapıyı kapatır. +/- 3 mm yükseklik ayarı yapılabilir. 90° 'de durur. Doğrama iç boşluğu min. 25x25mm olmalıdır. Üst menteşedeki ayar sayesinde alt menteşe olay takılabilmektedir

#### Hidden oildynamic doorcloser hinge. For framed doors with a stop.

New hidden oildynamic doorcloser hinge, for framed doors with a stop. The first Colcom hinge which is completely hidden into the profile, and adaptable to every project upon customer request. It maintains the same features as the Biloba Evo series hinges. Hydraulic Closing. Invisible - hidden into the profile. Customizable, in order to satisfy every specific project. Adjustability of the closing speed. Height regulation +/- 3 mm. 90° Stop. Minimum dimensions 25x25 mm. The installation of the upper hinge is completed by the dedicated hidden lower hinge.

#### Cerniera oleodinamica a scomparsa. Per porte con profili in battuta

Nuova Cerniera oleodinamica a scomparsa, per porte con profili in battuta. La prima cerniera di Colcom completamente "nascosta" nel profilo e adattabile ad ogni progetto su richiesta del cliente. Mantiene le consuete e garantite caratteristiche delle cerniere chiudiporta della serie Biloba Evo. Chiusura Oleodinamica. Invisibile perché nascosta nel profilo. Personalizzabile per soddisfare ogni progetto specifico del cliente. Regolazione della velocità di chiusura. Regolazione in altezza di +/- 3 mm. Stop a 90°. Misure minime di ingombro 25x25 mm. La cerniera superiore si accompagna ed è abbinata a quella inferiore dedicata.



#### art. 845E 10

- Gizli alt hidrolik menteşe. Binili alüminyum kapılar içindir. Ayarlanabilen kapanış hızı ve fren kontrolü. Kapı 180° ye kadar açılır. 90° ve 180° de durur.
- Hidden bottom hydraulic hinge. For framed doors with stop. Adjustable closing speed and constant braking control. The door opens up to 180° and stop at 90° and 180°.
- Cerniera oleodinamica a terra a scomparsa. Per porte con frame in battuta. Velocità di chiusura regolabile e controllo costante di frenatura; permette un'apertura porta fino a 180°. Stop a +90°, anche a 180° secondo progetto parete.



#### art. 845E 20

- Gizli üst menteşe. Binili alüminyum kapılar içindir. 845E10 ile birlikte kullanılır.
- Hidden top hinge. For framed doors with stop. To be matched with 845E10.
- Cerniera superiore a scomparsa. Per porte con frame in battuta. Da abbinare con 845E10.



## Unica

**HİDROLİK MENTEŞE**  
**OLDDYNAMIC HINGE - CERNIERA OLEODINAMICA**



### art. 101E10

Dış kapılarda kullanılmak üzere özenle tasarlanmış olan ürün, tüm cam kapı çeşitlerine monte edilebilir. Montajı son derece kolay ve hızlı olan ürün pivot kapılara da monte edilebilir. Biloba UNICA başka hiçbir ek elemana gerek duymaksızın, kapıyı otomatik olarak kapatır. Biloba UNICA, Maxima serisine ait tüm menteşe ve bağlantı elemanlarıyla kombine edilerek kullanılabilir. Otomatik kapatma mekanizmasını değiştirmeye gerek kalmadan ağır kapılar için tek bir menteşe yeterlidir. Çok geniş kapılar için pivot varyantı kullanılabilir. Kusursuz sağlamlık, güvenlik ve yer kazanımı sağlar. Biloba UNICA içerisinde; fren, kapanma hızı ayarlayıcısı ve sürgü ile yalnızca 56mm yüksekliktedir. Tüm standart yüzey bitiş seçeneklerine sahiptir.

Conceived for installation on exterior doors, this hinge features pure, essential design and is ideal for installation in any type of setting. It is extremely quick and easy to install in floor and pivot doors as well. Biloba UNICA does not require the installation of floor or overhead devices, yet it maintains the advantages of a closing system. Biloba UNICA can be combined to all patch fittings and top hinges in the Maxima series. A SINGLE hinge can be used to support heavy doors without having to change the closing mechanism, which remains automatic. The pivot variant can be mounted on very large doors, providing excellent stability, safety and minimum space. Biloba UNICA encompasses the brake, closing speed adjuster and final latch in a space only 56 mm high. Available in all standard finishes.

Nasce per le porte esterne, ma il suo formato e design minimale ne consentono l'applicazione in qualsiasi ambiente. Si distingue per la semplicità e rapidità di installazione a terra e può soddisfare anche applicazioni a bilico. Biloba UNICA consente di non installare alcun dispositivo né a pavimento né aereo, conservando però il beneficio dell'automatismo di chiusura. Biloba UNICA è abbinabile a tutti i patch fittings ed alla cerniera superiore serie Maxima. Con un'UNICA cerniera si sorreggono porte pesanti senza variare il comportamento di chiusura che resta automatico. La variante a bilico permette l'applicazione su vani porta più ampi, mantenendo massima stabilità e sicurezza in un minimo ingombro.

### avantajlar - benefits - vantaggi

#### ANKASTRE FREN

Built-in brake - Freno Integrato

#### FİNAL KAPANIŞ HIZI AYARI

Final latch adjustment - Regolazione scatto finale dell'anta

#### KAPANMA HIZI AYARI

Closing speed adjustment - Regolazione velocità di chiusura della porta

#### KAPI HİZALAMA AYARI

Door alignment adjustment - Regolazione allineamento della porta

#### EĞİM AYARI

Floor plate integrated tilting system - Placa de fijación con sistema basculante integrado

#### PİVOT UYGULAMA

Pivot application - Applicazioni a bilico

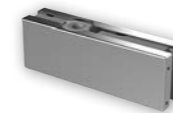

### art. 100E 20

- Taşıyıcı burç yatağı ile üst menteşe.
- Top hinge with adjustable bearing.
- Cerniera superiore con cuscinetto regolabile.



### art. 100E 25

- Travers bağlantı elemanı.
- Transom link fitting.
- Attacco al sopraluce.



### art. A100E 40

- 100E25 için duvar montaj plakası. 100E20 ile birlikte kullanılır.
- Wall mounting plate for item 100E25. To be combined with item 100E20.
- Piastrina per fissaggio a muro per attacco al sopraluce art.100E25. Da abbinare all'art.100E20.

## Triloba 0° +90° -90°

HİDROLİK MENTEŞE  
OILDYNAMIC HINGE - CERNIERA OLEODINAMICA



### art. 8201

- Kapının kapanış hızını ayarlanabilen hidrolik menteşe.
- Oildynamic hinge with adjustment of the closing speed of the door.
- Cerniera oleodinamica con regolazione delle velocità di chiusura dell'anta.



### art. 8202

- Fren için kontrol valfli hidrolik menteşe.
- Oildynamic hinge with control valve for brake.
- Dissipatore oleodinamico con regolazione dell'intensità frenante.



### art. 8204

- Üst kısım bağlantı parçası – binisiz duvar yanı.
- Upper-segment attachment-side wall without stop.
- Attacco sopra luce a muro laterale senza battuta.



### art. 8207

- Üst kısım bağlantı parçası – Binilli duvar yanı.
- Upper-segment attachment-side wall with stop.
- Attacco sopra luce a muro laterale con battuta.



### art. 8208

- Alt menteşe bağlantısı – cam yanı.
- Bottom hinge attachment-side glass.
- Attacco cerniera inferiore vetro laterale.



### art. 8209

- Üst menteşe bağlantısı – cam yanı.
- Upper hinge attachment-side glass .
- Attacco cerniera superiore vetro laterale.



### art. 8205

- Üst kısım bağlantısı – binisiz cam yanı.
- Upper segment attachment-side glass without stop.
- Attacco sopra luce a vetro laterale senza battuta.



### art. 8206

- Üst kısım bağlantısı – binilli cam yanı.
- Upper segment attachment-side glass with stop.
- Attacco sopra luce vetro laterale con battuta.

DIŞ KAPILAR İÇİN - İÇ GÖVDE TAMAMEN ELOKSAL. KAPAKLAR PASLANMAZ ÇELİK AISI 316  
FOR OUTER DOORS - COMPLETELY ANODIZED INNER BODY. COVERS MADE OF STAINLESS STEEL AISI 316  
PER PORTE ESTERNE - CORPO INTERNO COMPLETAMENTE ANODIZZATO. COPERTINA ESTERNA IN ACCIAIO INOX AISI 316

## Biloba 8010JC - 8015JC 0° +90° -90°

HİDROLİK MENTEŞE  
OILDYNAMIC HINGE - CERNIERA OLEODINAMICA

RÜZGÂR FRENİ YOK - NO ANTI-WIND BRAKE - NON DOTATA DI FRENO ANTIVENTO



### art. 8010JC

- Dış kapılar için kapanma hızı ayarlanabilir hidrolik menteşe.
- Hydraulic hinge with adjustment of the closing speed for outer doors.
- Cerniera oleodinamica con regolazione della velocità di chiusura per porte esterne.

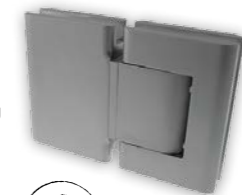

### art. 8015JC

- Dış kapılar için kapanma hızı ayarlanabilir hidrolik menteşe. (cam-cama).
- Hydraulic hinge (glass to glass) with adjustment of the closing speed of the door for outer doors.
- Cerniera oleodinamica (vetro-vetro) con regolazione delle velocità di chiusura dell'anta per porte esterne.



## MENTEŞE VE PARÇA BAĞLANTISI HINGE AND PATCH FITTING - CERNIERE E ATTACCHI SOPRALUCE



**art. 1010**

- 57-67 mm İtalyan yuvalı alt mil.
- Bottom pivot patch with Italian pivot housing at 57-67mm.
- Cerniera inferiore con quadro italiano a 57-67mm.



**art. 1730  
art. 1732  
art. 1735**

- Menteşeler için alt pim.
- Bottom pin for hinges
- Pilette per cerniera.



**art. 1011**

- P57-67 mm Alman pivotlu alt mil.
- Bottom pivot patch with German pivot at 57-67mm.
- Cerniera inferiore con tassello rettangolare tedesco.



**art. 1030**

- Köşe kilidi. 1010-1020 ile aynı boyutta ve kesimdedir.
- Corner lock. Same size and cut as 1010-1020.
- Serratura stesse dimensioni della 1010-1020.



**art. 1012**

- 57-67 mm İspanyol pivotlu alt mil.
- Bottom pivot patch with Spanish pivot at 57-67mm.
- Cerniera inferiore con tassello rettangolare spagnolo.



**art. 1040**

- 1020 için traverten duvara bağlantı parçası.
- Transom to wall link fitting for 1020.
- Attacco sopra-luce - muro per 1020.



**art. 1020**

- 57-67mm üst mil, ayarlanabilir yatak burcu ile.
- Top pivot patch with adjustable bearing bush at 57-67mm.
- Cerniera superiore cuscinetto a 57-67mm registrabile.



**art. 1050**

- 1020 için traverten sabit yan panele bağlantı parçası.
- Transom to fixed side panel link fitting for 1020.
- Attacco sopra-luce-vetro laterale per art.1020.

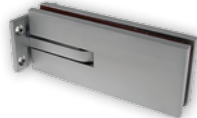

**art. 1022**

- Tavan bağlantısı olmayan kapılar için yan mil. 1010 ile uyumlu.
- Side pivot patch for doors without ceiling fixings. Combined to item.1010.
- Cerniera laterale per porte senza attacchi al soffitto. Abbinabile art.1010.



**art. 1060**

- Traverten tamponlu yan panele küçük bağlantı elemanı.
- Small link fitting for transom to side panel with stop.
- Attacco piccolo sopra-luce-vetro fisso laterale con battuta.



**art. 1027**

- 1020-1820 için üst mil.
- Top pin for 1020-1820.
- Piletta a soffitto per 1020-1820.



**art. 1065**

- Binili yan panele traverten küçük bağlantı elemanı.
- Small link fitting for transom to side panel without stop.
- Attacco piccolo sopra-luce-vetro fisso laterale senza battuta.

## MENTEŞE VE PARÇA BAĞLANTISI HINGE AND PATCH FITTINGS - CERNIERE E ATTACCHI SOPRALUCE



**art. 1070**

- Binili yan panele traverten küçük bağlantı elemanı.
- Small link fitting for transom to side panel with rebate.
- Attacco piccolo sopra-luce-muro con battuta.



**art. 1075**

- Binisiz duvara traverten küçük bağlantı elemanı.
- Small link fitting for transom to wall without rebate.
- Attacco piccolo sopra-luce-muro senza battuta.

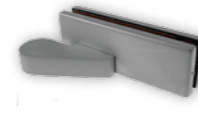

**art. 1510**

- Alt tek yönlü mil (sağ - sol).
- Bottom offset pivot patch. (right - left).
- Cerniera inferiore con perno spostato(DX-SX).

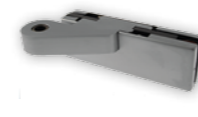

**art. 1520**

- Üst tek yönlü mil (sağ - sol).
- Top offset pivot patch. (right - left).
- Cerniera superiore con perno spostato(DX-SX).



**art. 1522**

- Üst tek yönlü mil.
- Top offset pivot patch.
- Cerniera superiore con perno spostato.



**art. 1527**

- 1520 için tek yönlü üst pim. (sağ - sol)
- Top offset pin for 1520. (right - left).
- Piletta superiore con perno spostato. Per art. 1520(DX-SX).

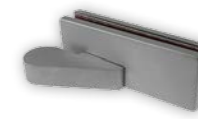

**art. 1518**

- Alt tek yönlü mil (sağ - sol). Binili.
- Bottom offset pivot patch. (right - left). With stop.
- Cerniera inferiore con perno spostato.(DX-SX) in battuta.



**art. 1528**

- Üst tek yönlü mil. Binili.
- Top offset pivot patch. With stop.
- Cerniera superiore con perno spostato. In battuta.

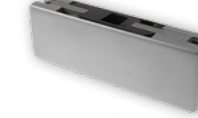

**art. 1810**

- Merkezi milli alt menteşe.
- Bottom hinge with central pivot.
- Cerniera inferiore a perno centrale.



**art. 1820**

- Merkezi milli, burç yataklı üst menteşe.
- Top hinge with central pivot with adjustable bearing.
- Cerniera superiore a perno centrale con cuscinetto registrabile.



**art. 1825**

- 1820 için travers bağlantı elemanı.
- Transom link fitting for 1820.
- Attacco al sopra-luce per art. 1820.

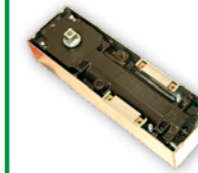

**art. 6072-90 , 6073-120**

- Yer hidroliği kod 6072-90, 6073-120
- Floor spring code 6072-90, 6073-120
- Chiudiporta cod. 6072-90, 6073-120

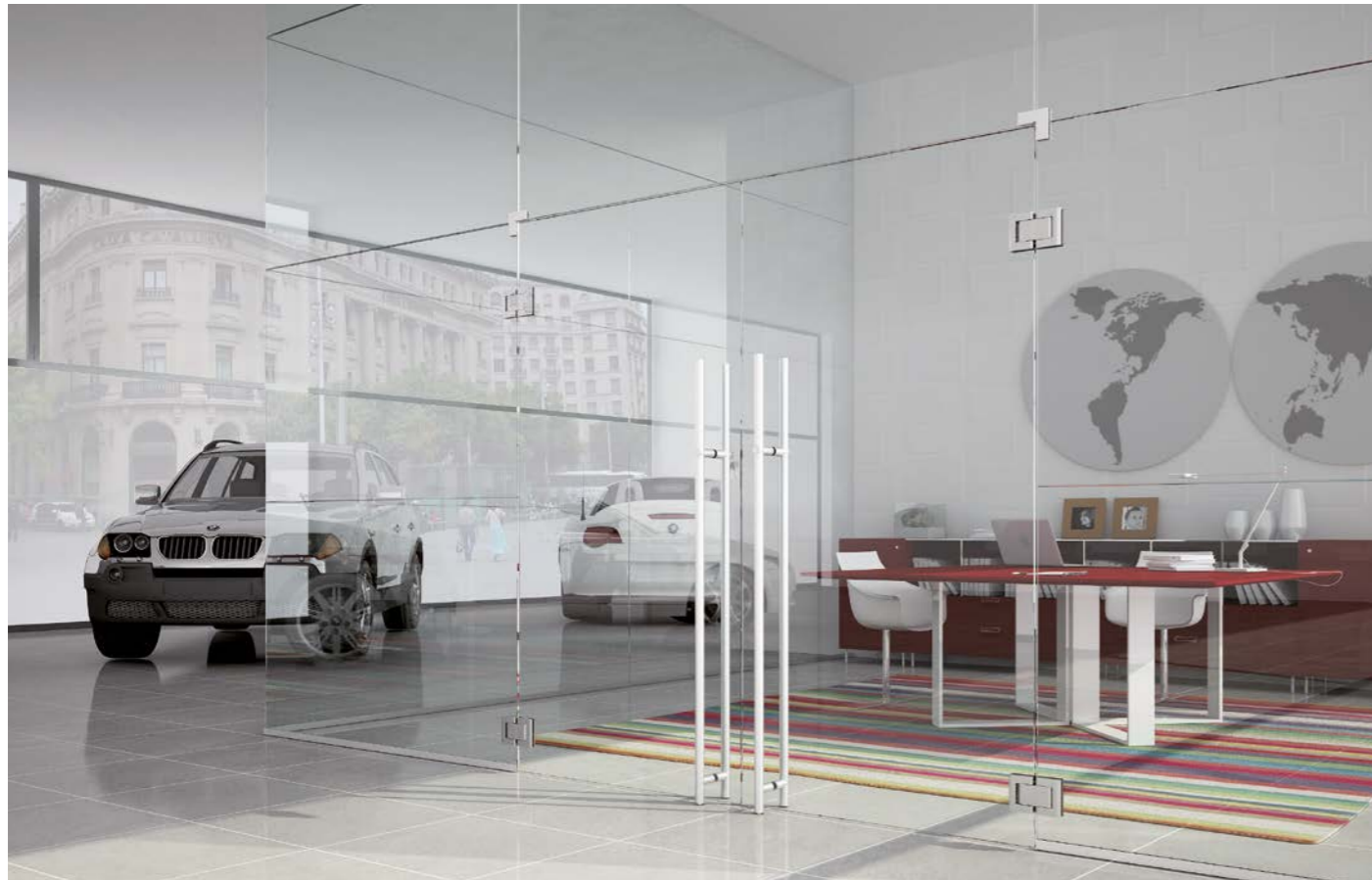
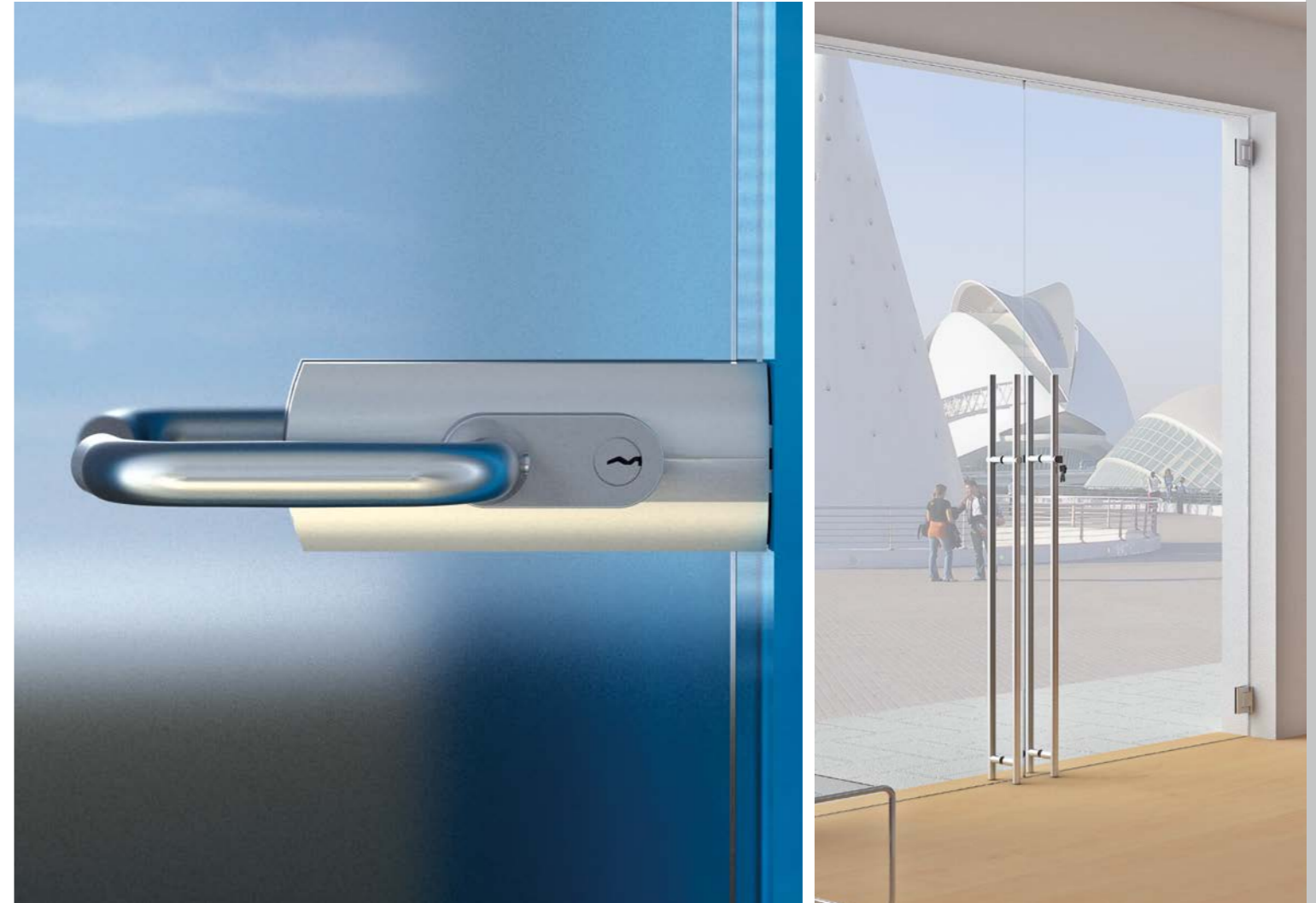

## KİLİTLER ve KOLLAR

Locks and Handles  
Serrature e Maniglioni

## ANAHTARLI KİLİTLER LOCKS WITH KEY - SERRATURE CON CHIAVE



### art. 6410

- Binili kapı için yatay kilit. Anahtar-anahtar. Kapı kolu dahildir.
- Horizontal lock for door with stop. Key-key. Handle included.
- Serratura orizzontale in battuta Chiave-chiave. Maniglia inclusa.



### art. 6411

- Binili kapı için yatay kilit. Anahtar-topuz. Kapı kolu dahildir.
- Horizontal lock for door with stop. Key-knob. Handle included.
- Serratura orizzontale in battuta Chiave-pomolo. Maniglia inclusa.



### art. 6411A

- Binili kapı için yatay kilit. Topuz-anahtar. Kapı kolu dahildir.
- Horizontal lock for door with stop. Knob-key. Handle included.
- Serratura orizzontale in battuta Pomolo-chiave. Maniglia inclusa.



### art. 6412

- Binili kapı için yatay kilit. Topuz - serbest/meşgul . Kapı kolu dahildir.
- Horizontal lock for door with stop. Knob-free/engaged. Handle included.
- Serratura orizzontale in battuta Pomolo-libero/occupato. Maniglia inclusa.



### art. 6412A

- Binili kapı için yatay kilit. Serbest/meşgul-Topuz . Kapı kolu dahildir.
- Horizontal lock for door with stop. Free/engaged-knob. Handle included.
- Serratura orizzontale in battuta Libero/occupato-pomolo. Maniglia inclusa.



### art. 6415

- Yatay kilit karşılığı FLEXA.
- Horizontal lock keeper FLEXA.
- Controserratura orizzontale FLEXA.



# Anahtarlı Kilitler

LOCKS WITH KEY - SERRATURE CON



## art. 620E 10

- Binili kapılar için düşey kilit. Anahtar -Anahtar.
- Vertical lock for door with stop. Key-key.
- Serratura verticale in battuta Chiave-chiave.



## art. 620E 50

- Düşey kilit karşılığı.
- Vertical lock keeper
- Controserratura verticale.



## art. 600E 10

- Kapı kolu.
- Handle.
- Manilla .



## art. 601E 10

- Kapı kolu.
- Handle.
- Manilla.



## art. 602E 10

- Zamak kapı kolu.
- Zamak handle.
- Manilla in zama.



# Manyetik Kilitler

MAGNETIC LOCK - SERRATURA MAGNETICA



## art. 622E 10

- Düşey anahtar-anahtar manyetik kilit. Binili kapılar için.
- Vertical lock key-key with magnetic latch for doors with jamb.
- Serratura verticale con scrocco magnetico chiave-chiave in battuta.



## art. 623E 10

- Düşey anahtar-anahtar manyetik kilit. Çift yöne açılan kapılar için.
- Vertical lock key-key with magnetic latch for double swing doors.
- Serratura verticale con scrocco magnetico chiave-chiave. Doppio senso di apertura.



## art. 0622E 10

- 622E10 için binili manyetik kilit karşılığı.
- Magnetic latch keeper with stop for art. 622E10.
- Riscontro magnetico in battuta per art. 622E10.



## art. 0622E 11

- 622E10 için duvara monte manyetik kilit karşılığı.
- Magnetic latch keeper for wall installation for art. 622E10.
- Riscontro magnetico a muro per art. 622E10.



## art. 0622E 12

- 622E10 için alüminyum profile montaj kilit karşılığı.
- Magnetic latch keeper for aluminium frames for art. 622E10.
- Riscontro magnetico stipiti in alluminio per art. 622E10.



## art. 622E 50

- Binili kapılar için cam cama binili kilit karşılığı.
- Magnetic vertical lock keeper for doors with stop. Glass to glass.
- Controserratura magnetica verticale in battuta.



## art. 623E 50

- Çift yöne açılan kapılar için cama cama manyetik kilit karşılığı.
- Magnetic vertical lock keeper for double swing doors. Glass to glass.
- Controserratura magnetica verticale doppio senso di apertura.

# LOQ Kilitler

LOCKS - SERRATURE



## art. 681WSC

- Binilli kapılar için yatay kilit. Kol ve barel deliği var.
- Horizontal lock with hole for handle and hole for cylinder.
- Serratura orizzontale in battuta con foro maniglia e foro cilindro.



## art. 681W01 - 681W02

- Binilli kapılar için yatay kilit. Kol deliği var.
- Horizontal lock with hole for handle only. For doors with stop.
- Serratura orizzontale in battuta solo foro maniglia.



## art. 681W50

- Cam cama binilli kilit karşılığı.
- Horizontal counter lock with stop.
- Controserratura orizzontale.



## art. 682WSC

- Binilli kapılar için yatay kilit. Kol ve barel deliği var.
- Horizontal lock with hole for handle and hole for cylinder.
- Serratura orizzontale in battuta con foro maniglia e foro cilindro.



## art. 682W01 - 682W02

- Binilli kapılar için yatay kilit. Kol deliği var.
- Horizontal lock with hole for handle only. For doors with stop.
- Serratura orizzontale in battuta solo foro maniglia.



## art. 682W50

- Cam cama binilli kilit karşılığı.
- Horizontal counter lock with stop.
- Controserratura orizzontale.



## art. 683WSC

- Binilli kapılar için yatay kilit. Kol ve barel deliği var.
- Horizontal lock with hole for handle and hole for cylinder.
- Serratura orizzontale in battuta con foro maniglia e foro cilindro.



## art. 683W01 - 683W02

- Binilli kapılar için yatay kilit. Kol deliği var.
- Horizontal lock with hole for handle only. For doors with stop.
- Serratura orizzontale in battuta solo foro maniglia.



## art. 683W50

- Cam cama binilli kilit karşılığı.
- Horizontal counter lock with stop.
- Controserratura orizzontale.



## art. 684WSC

- Binilli kapılar için yatay kilit. Kol ve barel deliği var.
- Horizontal lock with hole for handle and hole for cylinder.
- Serratura orizzontale in battuta con foro maniglia e foro cilindro.



## art. 684W01 - 684W02

- Binilli kapılar için yatay kilit. Kol deliği var.
- Horizontal lock with hole for handle only. For doors with stop.
- Serratura orizzontale in battuta solo foro maniglia.



## art. 684W50

- Cam cama binilli kilit karşılığı.
- Horizontal counter lock with stop.
- Controserratura orizzontale.

# LOQ Kilitler

LOCKS - SERRATURE



## art. 685W30

- Kırmızı/yeşil göstergeli WC kilit
- Lock for bathrooms with free/occupied pull. Quick and easy knob/coin inversion.
- Serratura per bagno con pomolo/coin con libero/occupato. Facile e veloce inversione pomolo-coin.



## art. S1671W10

- Barel anahtar/anahtar.
- Cylinder key/key.
- Cilindro chiave/chiave.



## art. S1671W21

- Barel anahtar/topuz
- Cylinder key/knob.
- Cilindro chiave/pomolo.



## art. S1671W23

- Barel anahtar/kör tapa banyolar için.
- Cylinder knob/coin for bathroom doors.
- Cilindro pomolo/coin per porte bagno.



## art. 607W

- Kare kol. İç mekanizma dahil.
- Square handle. Internal mechanism included.
- Maniglia sezione quadra. Quadro maniglia incluso.



## art. 608W

- Daire kesitli köşeli kol. İç mekanizma dahil.
- Rounded handle in a square shape. Internal mechanism included.
- Maniglia sezione tonda angolo quadro. Quadro maniglia incluso.



## art. 609W

- Daire kesitli kıvrık kol. İç mekanizma dahil.
- Rounded handle with rounded corner. Internal mechanism included.
- Maniglia sezione tonda angolo stondato. Quadro maniglia incluso.



## art. 610W

- Düz görünümlü kavramalı kol. İç mekanizma dahil.
- Flat handgrip handle. Internal mechanism included.
- Maniglia impugnatura piatta. Quadro maniglia incluso.

# Kilitler

LOCKS - SERRATURE



art. 6641

- İspanyolet sürgülü kilit ve kol yeri .
- Lock with latch bolt and handle seating.
- Serratura con scrocco con foro per maniglia.



art. 6650

- Kol yeri olan yatay kilit.
- Horizontal lock with handle seating.
- Serratura orizzontale con foro per maniglia.



art. 6855

- Kısa yatay kilit karşılığı.
- Short horizontal lock keeper.
- Controserratura orizzontale corta.



art. 6652

- Kapı kolu yeri olan yatay kilit. Binili kapılar için.
- Horizontal lock with handle seating. For doors with stop.
- Serratura orizzontale in battuta con foro per maniglia.



art. 6852

- Yatay kilit karşılığı.
- Horizontal lock keeper.
- Controserratura orizzontale.



art. 6603

- Paslanmaz çelik kapı kolu.
- Stainless steel handle.
- Maniglia in acciaio inox.



art. 6606

- Standart kapı kolu.
- Standard handle.
- Maniglia standard.



art. 6610

- Hareketsiz topuzlu kapı kolu.
- Handle with dead knob.
- Maniglia con pomolo in folle.



art. 6623

- "Meroni Forma" kilit.
- Lock "Meroni Forma".
- Serratura "Meroni FORMA".



art. 6628

- "Meroni Forma" kilit karşılığı.
- Lock keeper "Meroni Forma".
- Controserratura per "Meroni Forma".

# Kilitler

LOCKS - SERRATURE



art. 6730

- Hoppe Hcs kapı kolu için yatay adaptör.
- Horizontal adapter for Hoppe Hcs handle.
- Adattatore orizzontale per maniglie Hoppe Hcs.

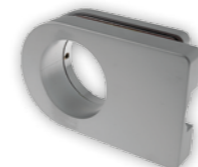

art. 6731

- Hoppe HCS kapı kolu için yatay yuvarlatılmış adaptör.
- Horizontal rounded adapter for Hoppe Hcs handle.
- Adattatore orizzontale tondo per maniglia Hoppe Hcs.



art. 6734

- Hoppe HCS kapı kolu adaptörü için yatay kilit karşılığı.
- Horizontal lock keeper for Hoppe HCS handle adapter.
- Controserratura orizzontale per adattatore maniglia Hoppe Hcs.



art. 6735

- Hoppe HCS kapı kolu adaptörü için yatay yuvarlak kilit karşılığı.
- Horizontal round lock keeper for Hoppe HCS handle adapter.
- Controserratura orizzontale tonda per adattatore maniglia Hoppe Hcs.



art. 6736

- Hoppe HCS kapı kolu seti, silindir ve topuz ile.
- Hoppe HCS handle set with cylinder and knob.
- Maniglie Hoppe Hcs completa di cilindro e pomello.



art. A69

- Küçük tutamaklı kilitleme sürgüsü.
- Locking bolt with small knob.
- Catenacciolo con pomolino.



art. A695

- A69 için cam cama karşılık.
- Locking bolt for A69.
- Contro catenacciolo per art. A69.



art. A86

- Anahtarlı sürgü mekanizması.
- Locking bolt with key.
- Catenacciolo con chiave.



art. B19

- Cam kesilmeden sürgü mekanizması. 8-10mm için. İsteğe bağlı olarak farklı kalınlıklar.
- Locking bolt without cut in the glass. For 8-10 mm.
- Catenacciolo senza tacca nel vetro. Per vetro da 8-10mm.



art. 6M10

- h:50mm manyetik kapı stoperi.
- Magnetic door stopper h50mm.
- Fermaporta magnetico h50mm.



art. 6M15

- 6M10/6M12 için manyetik plaka.
- Magnetic plate for 6M10/6M12.
- Controplastra magnetica per 6M10/6M12.



# Kilitler

LOCKS - SERRATURE



## art. 100E30

- Köşe kilididir. 100E10-100E20 ile aynı ebatta.
- Corner lock. Same size as art. 100E10-100E20.
- Serratura stessa dimensione dell'art. 100E10-100E20.



## art. 1030

- Köşe kilididir. 1010-1020 ile aynı ebatta.
- Corner lock. Same size as art. 1010 - 1020.
- Serratura stessa dimensione dell'art. 1010-1020.



## art. 6040

- Yuvarlatılmış çift dönüşlü yaysız kilit. Cam kesilmeden.
- Lock with rounded double turn dead bolt. Without cut in the glass.
- Serratura con chiavistello tondo doppia mandata senza tacca nel vetro.



## art. 6050

- 6040 için kilit karşılığı.
- Lock keeper for 6040.
- Controserratura per art. 6040.



## art. 6630

- Yuvarlatılmış çift dönüşlü yaysız kilit.
- Lock with rounded double turn dead bolt.
- Serratura con chiavistello tondo doppia mandata.



## art. 6830

- 6630 için kilit karşılığı.
- Lock keeper for 6630.
- Controserratura per art. 6630.



## art. 6835

- 6630 için kilit karşılığı. Binili.
- Lock keeper for 6630 with stop.
- Controserratura con battuta per art.6630.



## art. 6640

- Sürgü dilli ve tek dönüşlü yaysız kilit.
- Lock with latch bolt and single turn dead bolt.
- Serratura con scrocco più mandata.



## art. 6645

- (Olivetta) çift eğimli sürgü dilli ve tek dönüşlü yaysız kilit ile.
- Double bevelled (Olivetta) lock with latch bolt and single turn dead bolt.
- Serratura con doppio smusso (Olivetta) scrocco più mandata.



## art. 6840

- 6640-6641-6645 için kilit karşılığı.
- Lock keeper for 6640-6641-6645.
- Controserratura per art.6640-6641-6645.



## art. 6845

- 6640-6641-6645 için kilit karşılığı. Binili.
- Lock keeper for 6640-6641-6645. With stop.
- Controserratura con battuta per art. 6640-6641-6645.



## art. 6870

- 6640a uygun vuruşlu elektrik kontağı.
- Electric contact matching strike for 6640.
- Incontro elettrico per art. 6640.



## art. 6875

- 6630 için kilit karşılığı. Binili.
- Electric contact matching strike for 6640.
- Controserratura elettrica per art.6640.

# KOLLAR

HANDLES - TIRADORES - MANIGLIONI



## art. 5H01

- Kapı kolu çifti. Merkez uzaklığı 192mm. Paslanmaz çelik.
- Pair of handles. Centre distance 192mm. Stainless steel.
- Coppia maniglioni dritti. Interasse 192mm. Acciaio inox.



## art. 5H03

- Kapı kolu çifti. Merkez uzaklığı 250mm. Paslanmaz çelik.
- Pair of handles. Centre distance 250mm. Stainless steel.
- Coppia maniglioni dritti. Interasse 250mm. Acciaio inox.



## art. 5H11

- Kapı kolu çifti. Merkez uzaklığı 300mm. Paslanmaz çelik.
- Pair of handles. Centre distance 300mm. Stainless steel.
- Coppia maniglioni dritti. Interasse 300mm. Acciaio inox.



## art. 5H15

- Kapı kolu çifti. Merkez uzaklığı 900mm. Paslanmaz çelik.
- Pair of handles. Centre distance 900mm. Stainless steel.
- Coppia maniglioni dritti. Interasse 900mm. Acciaio inox.



## art. 5011

- Kapı kolu çifti. Merkez uzaklığı 300mm. Alüminyum.
- Pair of handles. Centre distance 300mm. Aluminium.
- Coppia maniglioni dritti. Interasse 300mm. Alluminio.



## art. 5L01

- Kapı kolu çifti. Merkez uzaklığı 300 x 600 mm. Alüminyum.
- Pair of handles L. Centre distance 300 x 600 mm. Aluminium.
- Coppia maniglioni ad L. Interasse 300 x 600 mm. Alluminio.

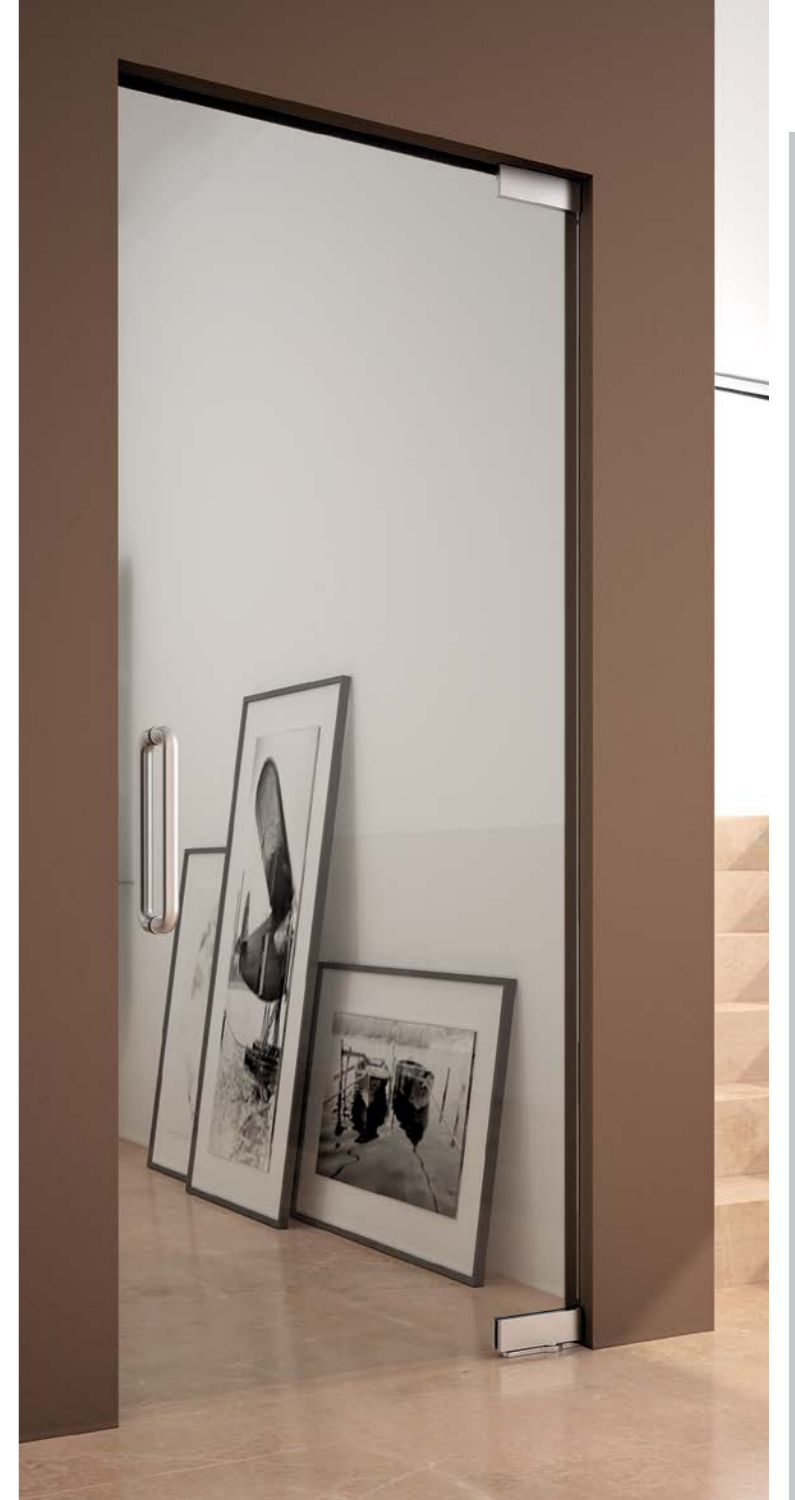

# Topuzlar ve Kapı Kolları

KNOBS and HANLDES - Pomoli e Maniglie



**art. 5005**

- 63mm çaplı küre kapı topuzu çifti.
- Pair of spherical door knobs. Diameter 63mm.
- Coppia pomoli a sfera. Diametro 63mm.



**art. 5006**

- 60mm çaplı kapı topuzu çifti.
- Pair of door knobs. Diameter 60mm.
- Coppia pomoli diametro 60mm.



**art. 5510**  
**art. 5511**

- Kapı kolu çifti. Alüminyum.
- Merkez uzaklığı 300mm.
- Pair of handles. Aluminium.
- Centre distance 300mm.
- Coppia maniglioni dritti. Alluminio.
- Interasse 300mm.

**art. 5514**  
**art. 5515**

- Kapı kolu çifti. Alüminyum.
- Merkez uzaklığı 900mm.
- Pair of handles. Aluminium.
- Centre distance 900mm.
- Coppia maniglioni dritti. Alluminio.
- Interasse 900mm.



# Anahtarlı Kapı Kolları

HANDLES WITH KEY - MANIGLIONI CON CHIAVE



**art. 500W 51**

- Kilitli kapı kolu çifti. Anahtar-anahtar. U=1500mm. Paslanmaz çelik. Ø35mm.
- Pair of handles with lock. Key-key. L=1500mm. Stainless steel. Ø35mm.
- Coppia maniglioni dritti con serratura. Chiave-chiave. L=1500mm. Acciaio inox. Ø35mm.



**art. 500W 50**

- Kilitli kapı kolu çifti. Anahtar-topuz. U=1500mm. Paslanmaz çelik. Ø35mm.
- Pair of handles with lock. Key-knob. L=1500mm. Stainless steel. Ø35mm.
- Coppia maniglioni dritti con serratura. Chiave-pomolo. L=1500mm. Acciaio inox. Ø35mm.



**art. 501W 50**

- Kilitli kapı kolu çifti. Anahtar-topuz. U=2200mm. Paslanmaz çelik. Ø35mm.
- Pair of handles with lock. Key-knob. L=2200mm. Stainless steel. Ø35mm.
- Coppia maniglioni dritti con serratura. Chiave-pomolo. L=2200mm. Acciaio inox. Ø35mm.

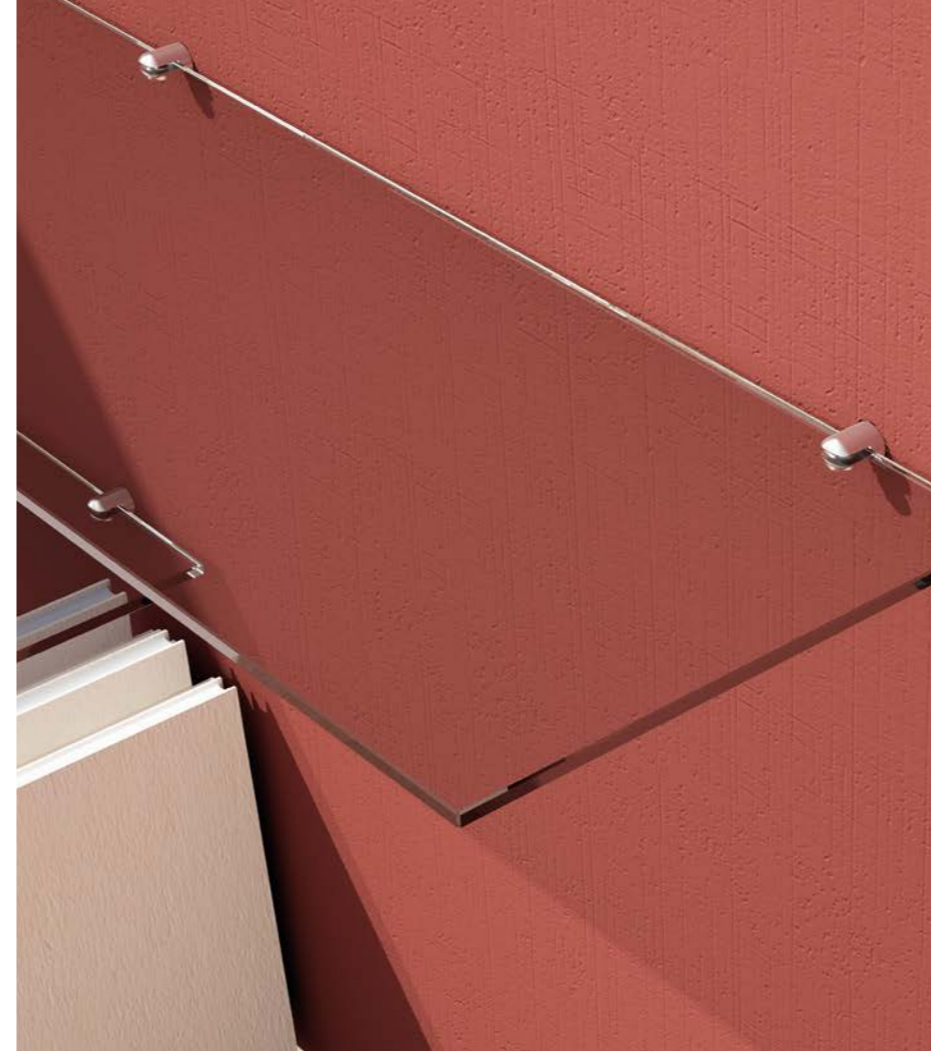

**Mobilya**

Furnishing  
Arredo

# Vitrinler

SHOW WINDOWS - VETRINE



**art. B43**

- 6 mm cam için küçük mil.
- Small pivot patch for 6 mm glass.
- Cernierina per vetro da 6 mm.



**art. B735**

- Raf kelepçesi. - çap.20mm. Küçük raf için.
- Clamp for angle bracket - round diam.20 mm. For small shelf.
- Morsetto reggimensola tondo diametro 20mm. Per piccoli ripiani.



**art. B46**

- 6-8 mm cam için tek dönüşlü yaysız kilit.
- Lock for 6-8 mm glass with single turn dead bolt.
- Serratura per vetro da 6-8 mm una mandata.



**art. B73**

- Raf kelepçesi.- çap.22mm. Küçük raf için.
- Clamp for angle bracket - round diam.22 mm. For small shelf.
- Morsetto reggimensola tondo diametro 22mm. Per piccoli ripiani.



**art. B46**

- Raf desteği için dübel. Polikarbon (10 Parça)
- Shelf support dowel.Polycarbonate.(10Pieces)
- Tassello sostegno ripiani. Policarbonato (10PZ)



**art. B83**

- Raf kelepçesi.- L= 20mm. Küçük raf için.
- Clamp for angle bracket - L = 20 mm. For small shelf.
- Morsetto reggimensola L=20mm. Per piccoli ripiani.

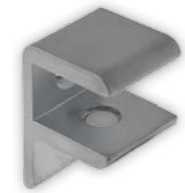

**art. B835**

- Raf kelepçesi.- L= 45mm. Küçük raf için.
- Clamp for angle bracket - L = 45 mm. For small shelf.
- Morsetto reggimensola L=45mm. Per piccoli ripiani.

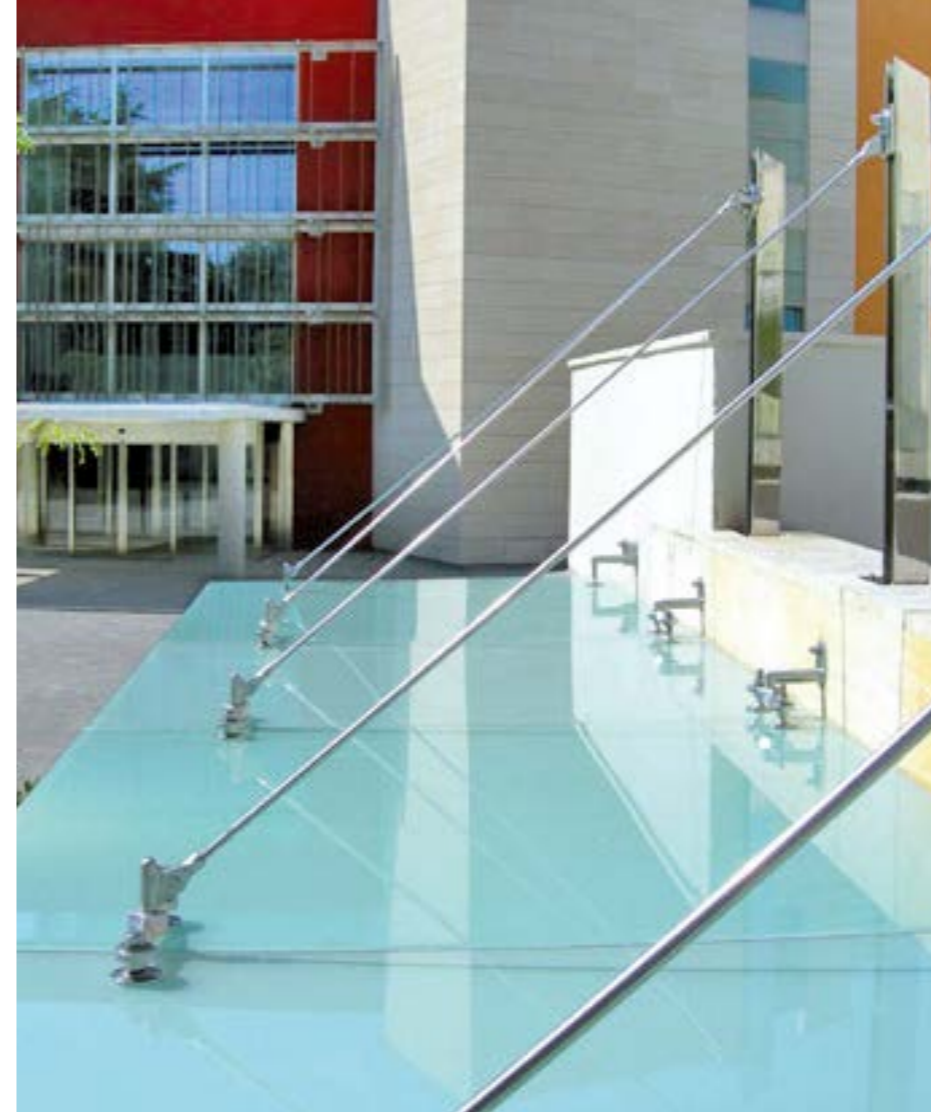

## Dış Mekan Aksesuarları

Street Furniture  
Arredo Urbano

# CAM TUTUCULAR

FASTENING SYSTEMS - SISTEMI DI FISSAGGIO

## AYARLANABİLİR AÇILILAR - ADJUSTABLE ANGULARS ANGOLARI REGOLABILI



art. M00W 10

- Ayarlanabilir açılı cam-zemin
- Adjustable angular glass-floor.
- Angolare regolabile vetro-pavimento.



art. M00W 30

- Ayarlanabilir açılı 3 yollu.
- Adjustable angular at 3 ways.
- Angolare regolabile a 3 vie.



art. M00W 20

- Ayarlanabilir açılı cam-cama.
- Adjustable angular glass to glass.
- Angolare regolabile vetro-vetro.



art. M00W 21

- Ayarlanabilir açılı 2 yollu.
- Adjustable angular at 2 ways.
- Angolare regolabile a 2 vie.



art. M00W 11

- Ayarlanabilir açılı cam-tavan.
- Adjustable angular glass-ceiling.
- Angolare regolabile vetro-soffitto.

## SABİT AÇILILAR - FIXED ANGULARS ANGOLARI FISSI



art. M01W 20

- 180° hatta cam-cama.
- Glass to glass fastening on 180° line.
- Fissaggio vetro-vetro in linea 180°.

## NOKTASAL TUTUCULAR - WALL POINTS PUNTI A MURO



art. 430W20

SAPLAMA CAM İLE HEMİYÜZ - STUD OF THE END  
PART OF THE GLASS - BORCHIA FILO VETRO

- Sabit cam paneller için paslanmaz çelik cam tutucu . 6 farklı ebat (20-30-40-50-70-100mm).
- Stainless-steel wall point, to fix plates and panels made of glass. Available in 6 lengths (20-30-40-50-70-100mm).
- Punto a muro in acciaio inox, per fissare targhe e pannelli in vetro. Disponibile in 6 lunghezze (20-30-40-50-70-100mm)



art. M01W 10

- 90° açılı cam-duvar.
- Fixed angular at 90° glass to wall.
- Angolare fisso 90° vetro-muro.



art. 431W20

SAPLAMA CAMIN DIŞINDA  
EXTERNAL STUD - BORCHIA ESTERNA



art. M01W 21

- 90° açılı cam-cama.
- Fixed angular at 90° glass to glass.
- Angolare fisso 90° vetro-vetro.

# SABCO Korkuluk

KORKULUK - BALUSTRADES - BARANDILLAS



SABCO, Sadev Korkuluk konsepti çerçevesiz korkuluklar için duvar ve cam montajı yapılabilir şekilde dizayn edilmiştir. Havalimanı, stadyum ve alışveriş merkezi gibi genel kullanıma açık mekanlar için uygundur. Maksimum şeffaflık ve yüksek seviyede güvenlik içerir. Sektörün tüm teknik ve kalite standartları için gereklilikleri sağlar.

SABCO, Sadev Balustrade Concept, is the system for frameless glass balustrade, available for wall and floor mounting. It is particularly suitable for public applications such as airports, stadiums, shopping centers and buildings. Maximum transparency and high level of security. SABCO has been tested to meet all technical and certification requirements of the market.

SABCO, Sadev Balustrade Concept, è il sistema di balastra in vetro senza telaio nelle versioni a muro e a pavimento. È particolarmente adatto per applicazioni pubbliche quali aeroporti, stadi, centri commerciali ed edifici. Massima trasparenza e alto grado di sicurezza. SABCO è stato progettato per soddisfare tutti i requisiti tecnici e di certificazione richiesti del mercato.













Bildiğiniz gibi cam saçaklar binanın cephesine modern bir dokunuş sağlar. 3 setin birleşimi size tek veya çok camlı olarak uygulayabileceğiniz farklı çözümler sunar. Ebat ve kapasite hesapları gibi sorularınız için teknik bölümümüzden destek alabilirsiniz.

As you know the cantilever made of glass confire a final and modernity touch to the front building. The compounding of the three existing sets allows different solutions that may be single or multiple plate. Further and special requests concerning dimensions or capacity may be calculated and supported by our technical department.

Le pensiline in vetro, come è noto, conferiscono alle facciate degli edifici un tocco di classe e di modernità. Esistono sostanzialmente tre kit, i quali combinati fra loro consentono diverse soluzioni, monolastra o multilastra. Richieste particolari per dimensione o portata, possono essere comunque calcolate e supportate dal nostro ufficio tecnico.



|   |  |   |   |
|---|--|---|---|
| <p><b>02</b></p>  <p>Natural<br/>Satin Anodized Aluminium<br/>Naturale<br/>Naturfarbe</p>    | <p><b>05</b></p>  <p>Siyah<br/>Black<br/>Nero<br/>Schwarz</p>   | <p><b>13</b></p>  <p>Satine Paslanmaz Çelik Görünümlü PVD<br/>Imitation stainless steel - PVD<br/>Simil inox satinato PVD<br/>Niro ähnlich - PVD</p> | <p><b>14</b></p>  <p>Krom Kaplama<br/>Polished Chrome<br/>Cromato lucido<br/>Glanz verchromt</p>                         |
| <p><b>15</b></p>  <p>Mat Krom Kaplama<br/>Matchrome<br/>Cromato opaco<br/>Matt verchromt</p> | <p><b>16</b></p>  <p>Parlak Altın PVD<br/>Imitation polished gold - PVD<br/>Oro lucido PVD<br/>Messing poliert Effekt - PVD</p> | <p><b>31</b></p>  <p>Satine Paslanmaz Çelik<br/>Satin stainless steel<br/>Acciaio inox satinato<br/>Edelstahl matt</p>                               | <p><b>32</b></p>  <p>Parlak Paslanmaz Çelik<br/>Bright stainless steel<br/>Acciaio inox lucido<br/>Edelstahl poliert</p> |

Firma ürün özelliklerini teknik gelişime bağlı olarak herhangi bir bildirimde bulunmaksızın değiştirme hakkını saklı tutar. Daha detaylı ve güncel bilgi için, teknik departmanımızla iletişime geçiniz.

The company reserves the right to introduce changes without notice on the basis of the technical development of the products. We suggest to consult the technical department for updates and more information on the technical data sheets.

---

---

---

**bm** ■ ■ ■  
**CAM**®  
D O N A N I M L A R I

BM CAM DONANIMLARI SAN. ve TİC. LTD. ŞTİ.  
Ahmet Yesevi Mah. Demokrasi Cad. No:127/2  
Sultanbeyli / İstanbul  
Tel: 0216 498 80 51 - 0216 498 85 94  
Faks: 0216 498 80 52  
info@bmofis.com - www.bmofis.com

